

MODEL
CSAD

Single ball shuttle valve with signal at port 2
CAPACITY: 10 L/min. | CAVITY: T-11A

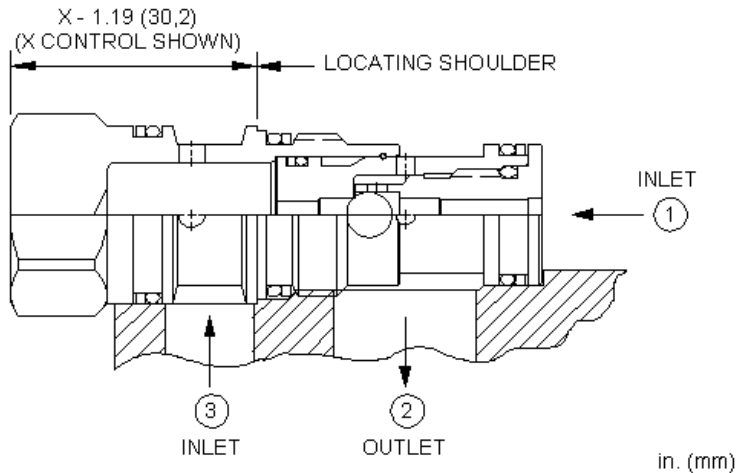
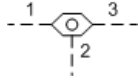

CONFIGURATION

X	Control	Not Adjustable
X	Adjustment Range	-
N	Seal Material	Buna-N
(none)	Material/Coating	Standard Material/Coating

The single ball shuttle connects the higher of two work ports to the signal or common port. The signal is sensed at port 2.

TECHNICAL DATA

Cavity	T-11A
Series	1
Capacity	10 L/min.
Maximum Operating Pressure	350 bar
Maximum Valve Leakage at 110 SUS (24 cSt)	0,3 cc/min.
Valve Hex Size	22,2 mm
Valve Installation Torque	41 - 47 Nm
Seal kit - Cartridge	Buna: 990-011-007
Seal kit - Cartridge	Polyurethane: 990-011-002
Seal kit - Cartridge	Viton: 990-011-006
Model Weight	0.11 kg.

SYMBOLS

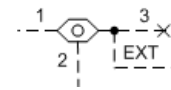
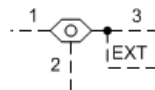
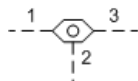

TECHNICAL FEATURES

- Shuttle cartridges feature hardened steel balls and seats for excellent wear characteristics and contamination tolerance.
- The single ball allows for the decay of the pressure signal when both load ports drop to a lower pressure.
- Incorporates the Sun floating style construction to minimize the possibility of internal parts binding due to excessive installation torque and/or cavity/cartridge machining variations.

PERFORMANCE CURVES

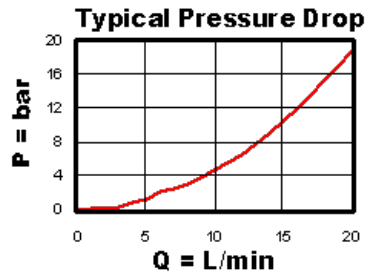
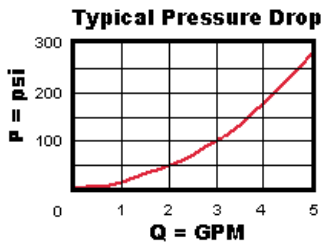

CONFIGURATION OPTIONS

CONTROL

Standard Options	A	Auxiliary External -4 SAE Port
	B	Auxiliary External 1/4 BSPP Port
	X	Not Adjustable

ADJUSTMENT RANGE

Standard Options	X	-
------------------	---	---

SEAL MATERIAL

Standard Options	N	Buna-N
	V	Viton

MATERIAL/COATING

Standard Options		Standard Material/Coating
	/AP	Stainless Steel, Passivated
	/LH	Mild Steel, Zinc-Nickel

Copyright © 2002-2014 Sun Hydraulics Corporation. All rights reserved.