



VUBA Sicherheitsventile für Leitungen

Предохранительные клапаны для труб



Technische Daten

Технические характеристики

Hydrauliköl Минеральное масло	ISO 6743/4 DIN 51524
Viskosität der Flüssigkeit Вязкость жидкости	10-500 mm ² /s 45 to 2000 ssu (6 to 420 cSt)
Max. Reinheitsklasse mit Filter Класс макс. загрязнения с фильтром	ISO 4406:1999 Klasse Класс 19/17/14
Temperatur der Flüssigkeit Температура жидкости	-20°C +80°C -4°F + 176°F
Umgebungstemperatur Температура окружающей среды	-20°C +50°C -4°F + 122°F
Die Verwendung eines Filters (empfohlene Filterung 15 Mikron) zum Schutz des Ventils ist unerlässlich. Необходимо применение фильтра для защиты клапана (рекомендуемая фильтрация 15 микрон)	
Leckage Утечка	0 - 0,25 cm ³ /min (0-0,015 in ³)

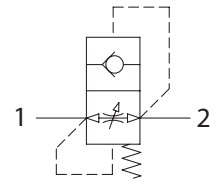

Größe / Размеры

Code Код	A	Gewicht / Kg Вес / lb
61700001	VUBA 140	0,12 (0.27)
61700002	VUBA 380	0,13 (0.29)
61700003	VUBA 120	0,15 (0.33)
61700004	VUBA 340	0,18 (0.40)

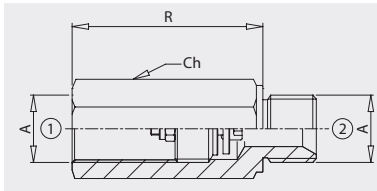
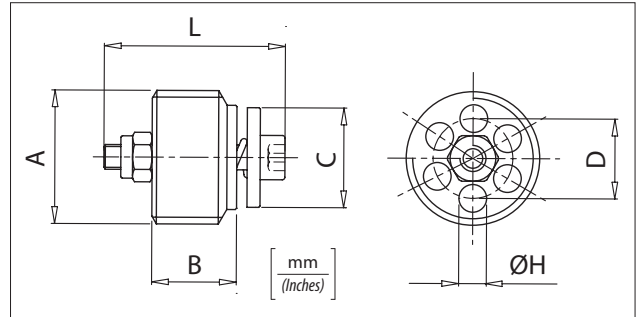

Gehäuse / Корпус HP/BP

Code Код	A	R	CH	Gewicht/Kg Вес / lb
61100087	BSPP 1/4	39 (1.53)	19 (0.75)	0,07 (0.16)
61100088	BSPP 3/8	45 (1.77)	22 (0.87)	0,09 (0.20)
61100089	BSPP 1/2	52 (2.05)	27 (1.06)	0,15 (0.33)
61100090	BSPP 3/4	61 (2.40)	32 (1.26)	0,23 (0.50)

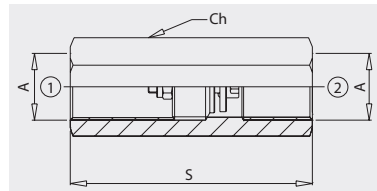

Gehäuse / Корпус BP/BP

Code Код	A	S	CH	Gewicht / Kg Вес / lb
61100092	BSPP 1/4	48 (1.89)	41 (1.61)	0,07 (0.16)
61100093	BSPP 3/8	54 (2.13)	19 (0.75)	0,09 (0.20)
61100094	BSPP 1/2	73 (2.87)	22 (0.87)	0,14 (0.30)
61100095	BSPP 3/4	74 (2.91)	27 (1.06)	0,22 (0.48)
61100091	BSPP 1	67 (2.63)	32 (1.26)	0,3 (0.65)

Bestellcode / Код заказа

VUBA - X - Y - K

X	Größe Размер
140	BSPP 1/4
380	BSPP 3/8
120	BSPP 1/2
340	BSPP 3/4
100	BSPP 1
1215	M12x1.5
1415	M14x1.5
1615	M16x1.5
2215	M22x1.5

K	Öffnung an Teller Отверстие на тарелке
	Beispiel: Öffnung 1,5 mm Пример: отверстие 1.5 mm
P	P 1,5 Weglassen, falls nicht erforderlich Упустить, если не требуется

Y	Einstellung Регулировка
F	Beispiel: Einstellung 0,7 mm Пример: регулировка 0.7 mm F 0,7 Weglassen, falls nicht erforderlich Упустить, если не требуется

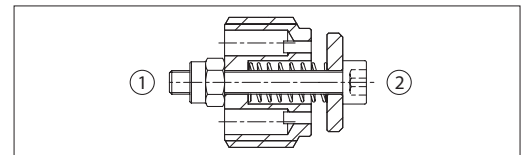
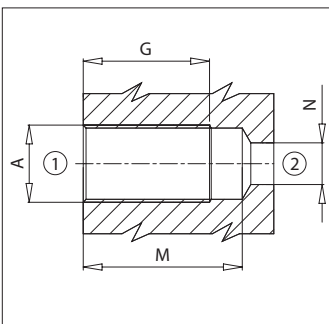
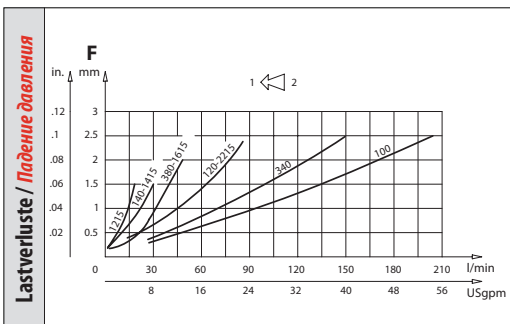
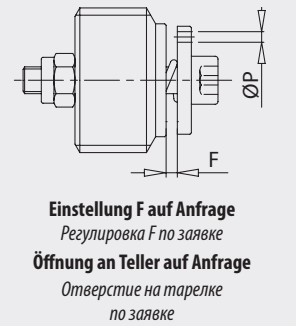

Technische Eigenschaften / Технические характеристики

Code Код	A	Max. Durchsatz Мак. проп. спос. l/min-USgpm	Max. Druck Мак. давление bar/PSI	B	C	D	G	H	L	M	N	Anzugsmoment Момент затяжки Nm / lbt ft	Ungefähres Gewicht Ориент. вес Kg / lb
VUBA 140	BSPP 1/4	25 (6.5)	350 (5000)	8,2 (0.32)	10,4 (0.41)	8 (0.31)	25 (0.98)	2,5 (0.10)	19 (0.75)	35 (1.38)	7 (0.28)	2 (1.5)	0,007 (0.016)
VUBA 380	BSPP 3/8	50 (13)		11 (0.43)	12,7 (0.50)	10 (0.39)	30 (1.18)	3,25 (0.13)	23 (0.90)	41 (1.61)	9,5 (0.37)	3 (2.5)	0,013 (0.029)
VUBA 120	BSPP 1/2	80 (21)		13 (0.51)	15 (0.59)	11,5 (0.45)	33 (1.30)	4 (0.16)	29 (1.14)	46 (1.81)	12 (0.47)	4 (3)	0,024 (0.053)
VUBA 340	BSPP 3/4	150 (40)		18 (0.71)	18 (0.71)	14,5 (0.57)	42 (1.65)	5,2 (0.20)	34 (1.34)	55 (2.17)	16 (0.63)	10 (7.5)	0,054 (0.12)
VUBA 100	BSPP 1	180 (47)		20 (0.79)	26 (1.02)	19 (0.75)	48 (1.89)	7 (0.28)	40 (1.57)	63 (2.48)	22 (0.87)	12 (9)	0,1 (0.22)
VUBA 1215	M12x1.5	15 (4)		8,4 (0.33)	10 (0.39)	7,5 (0.29)	25 (0.98)	1,6 (0.06)	19 (0.75)	35 (1.38)	7 (0.28)	2 (1.5)	0,007 (0.016)
VUBA 1415	M14x1.5	25 (6.5)		11 (0.43)	11,5 (0.45)	9 (0.35)		2,5 (0.10)	23 (0.90)				0,012 (0.027)
VUBA 1615	M16x1.5	50 (13)		13 (0.51)	15 (0.59)	10 (0.39)	30 (1.18)	3,25 (0.13)	29 (1.14)	41 (1.62)	9,5 (0.37)	3 (2.5)	0,012 (0.027)
VUBA 2215	M22x1.5	80 (21)		13 (0.51)	15 (0.59)	11,5 (0.45)	33 (1.30)	4 (0.16)	29 (1.14)	46 (1.18)	12 (0.47)	4 (3)	0,029 (0.064)