

La pompa viene fornita con leva di azionamento L=500 mm  
The pump is supplied with acting lever 19,6 in long

Codice ordinazione  
Ordering code

01

**PME10**

01	Pompe a mano (Cartridge hand pumps)	PME10
----	-------------------------------------	-------

**Schema idraulico - Hydraulic circuit**

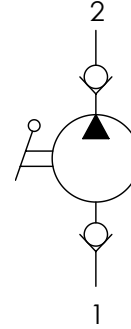

**Dati tecnici - Technical data**

Olio idraulico/Mineral oil	ISO 6743/4 (DIN 51524)	
Viscosità olio/Oil viscosity	15-250 mm <sup>2</sup> /s (15 to 250 cSt)	
Classe di contaminazione max con filtro Max contamination index with filter	ISO 4406:1999 Classe 19/17/14	
Temperatura dell'olio/Oil temperature	-20°C +80°C	-4°F + 176°F
Temperatura ambiente/Ambient temperature	-20°C +50°C	-4°F + 122°F
È indispensabile l'utilizzo di un filtro per proteggere la valvola (filtrazione consigliata 15 µm) It is necessary a filter use to protect the valve (advised filtration 15 µm)		

**Caratteristiche tecniche - Technical characteristics**

Tipo Type	Cilindrata Displacement cm <sup>3</sup> /in <sup>3</sup>	Pressione max Max pressure bar/PSI	Peso approssimativo Approx weight kg/lb	Coppia di serraggio Tightening torque Nm/lbf ft	Cavità Cavity
<b>PME10</b>	10 (0.6)	200 (2900)	1,9 (4.20)	41-47 (30-35)	SAE10/2

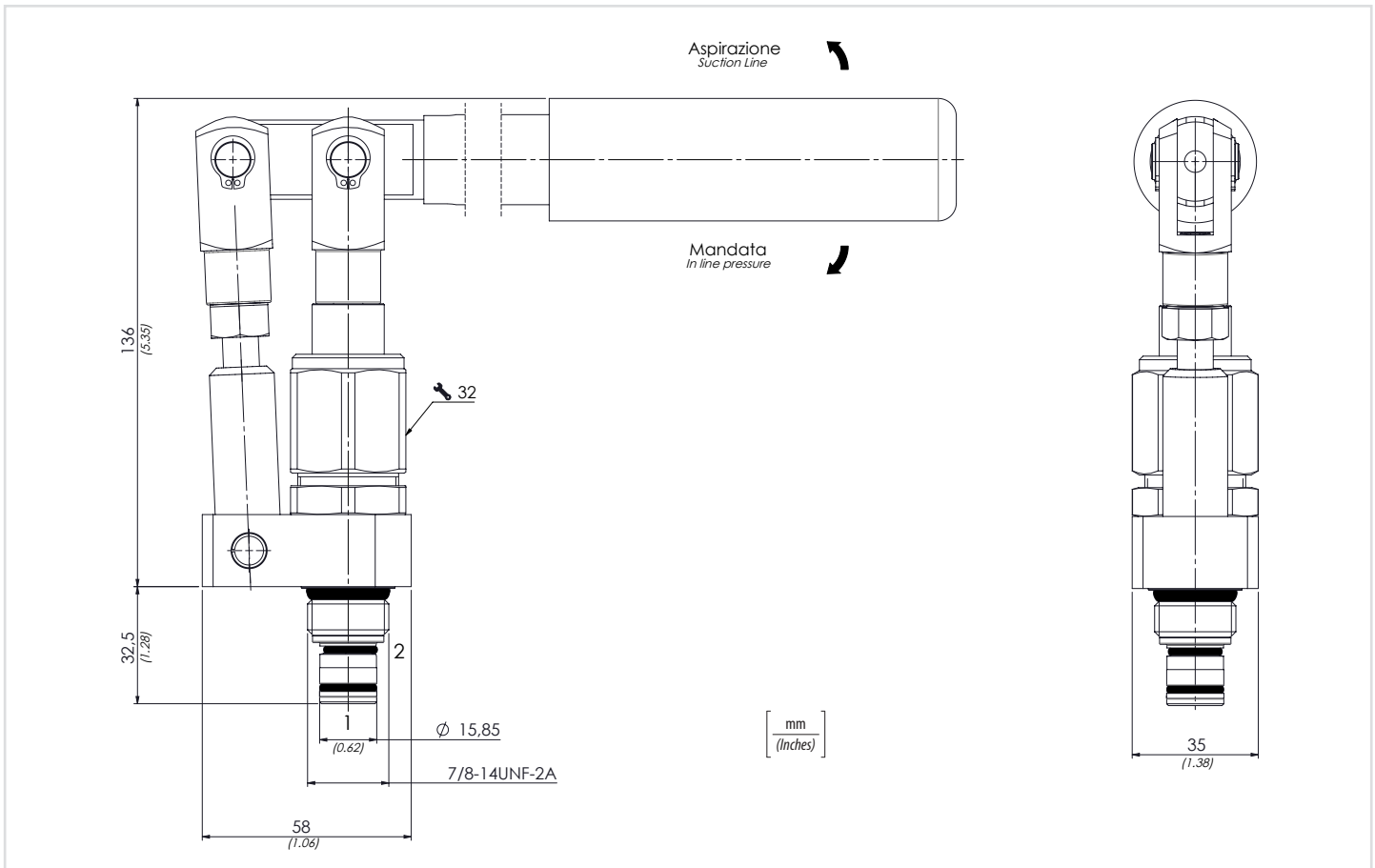

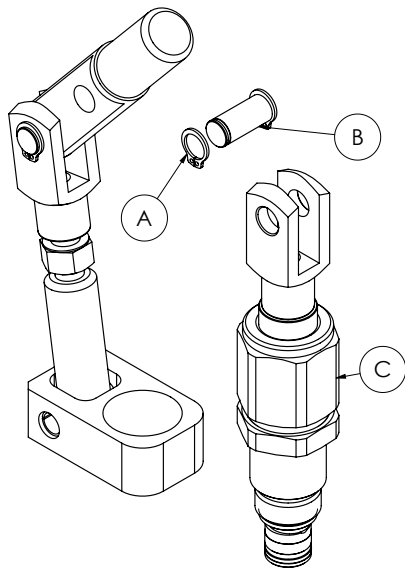

1

Smontare l'anello di arresto (A), sfilare la spina (B), togliere la valvola (C).

*Disassemble the snap ring (A), get out the pin (B), remove the valve (C).*

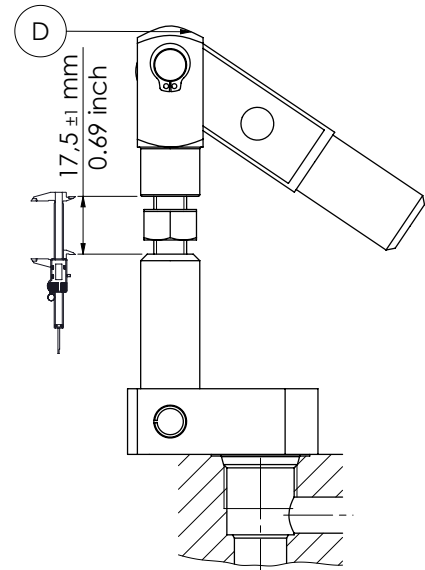

2

Posizionare la forcella (D) alla misura indicata; avvicinare il leverismo alla cavità della valvola.

*Position the fork (D) at shown dimension; put the levering kit close to the valve cavity.*

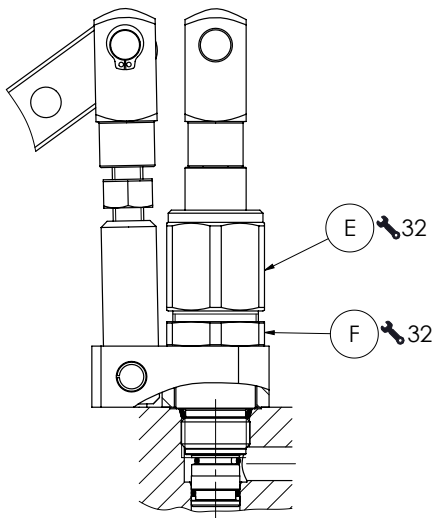

3

Avvitare la cartuccia (E) nella cavità (41-47 Nm); stringere la ghiera (F) (41-47 Nm).

*Screw the cartridge (E) in the cavity (30-35 lbft); tighten the lock nut (F) (30-35 lbft).*

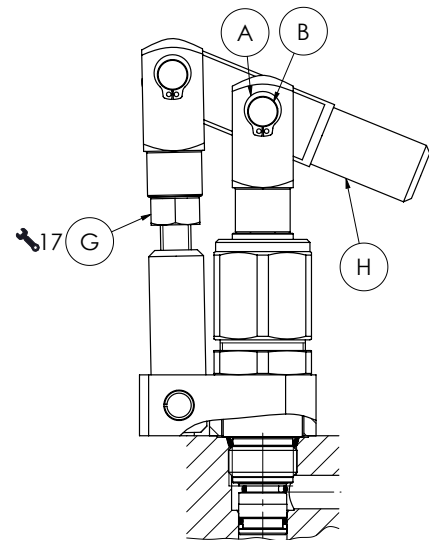

4

Posizionare la leva (H) verso il basso; montare la spina (B) e l'anello di arresto (A); serrare il dado (G) (33-53 Nm).

*Place the lever (H) downward; assemble the pin (B) and the snap ring (A); tighten the nut (G) (45-72 lbft).*