

SERIE LPC10 VALVOLA A CARTUCCIA - LPC10 SERIE- CARTRIDGE VALVE

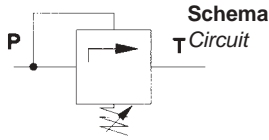

Codice Code	Q max. lt/min.	P max. Bar	Attacchi Port size	CAVITA CAVITY
LPC10	80	300	M26x1,5	n°13

Versione **V**
Version

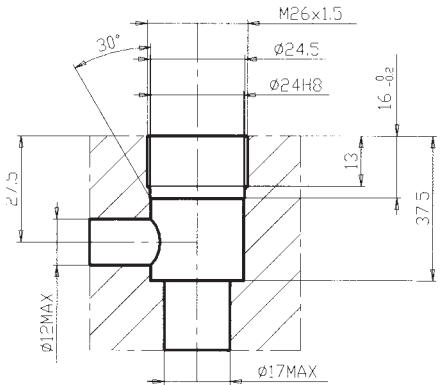
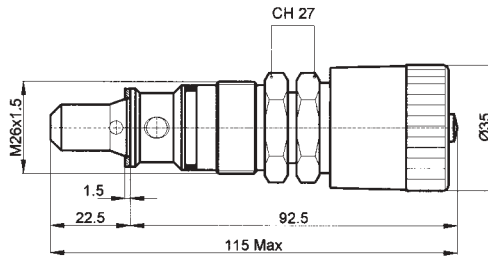
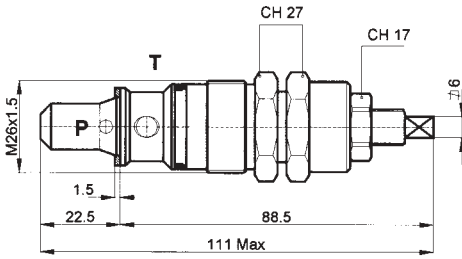

Codice ordinazione Order code	Peso Weight Kg.	Codice ordinazione Order code Versione V Version	Peso Weight Kg.	Campo di taratura Pressure range Bar	Coppia di serraggio Installation torque Nm
LPC10/60 LPC10/140 LPC10/200 LPC10/300	0,210	LPC10V/60 LPC10V/140 LPC10V/200 LPC10V/300	0,260	0 > 60 10 > 140 20 > 200 50 > 300	85 > 95

Rondella rame, fornita su richiesta.
Copper washer, on request

VALVOLA IN LINEA - LINE MOUNTED VERSION

Codice Code	A m/m	C m/m	B m/m	Attacchi Port size ØF BSPP	H m/m	I m/m	L m/m	M m/m	O m/m	ØN m/m	X m/m	X1 m/m	Peso Weight Kg
LPC10.../C12	40	60	80	1/2"	27,5	58	68	48	21	6,5	136,5	131	0,618
LPC10.../C34	40	60	80	3/4"	27,5	58	68	48	21	6,5	136,5	131	0,578

Codice di ordinazione per versione a volantino
Ordering code for version with wheel
LPC10V.../C

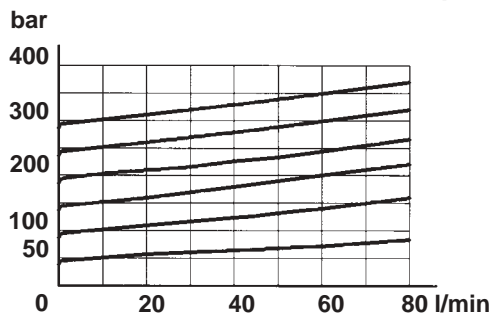
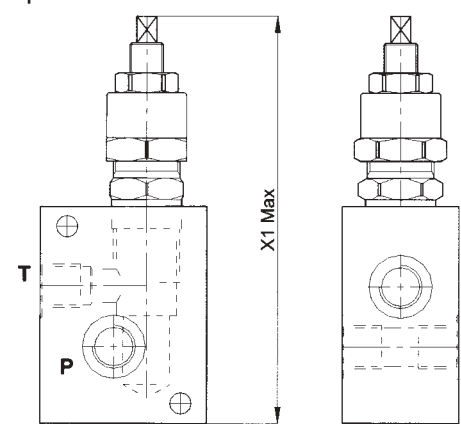
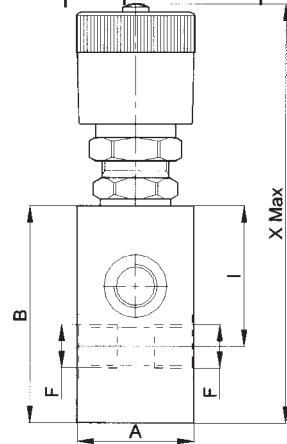
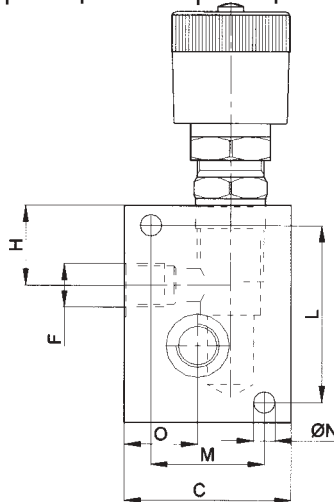
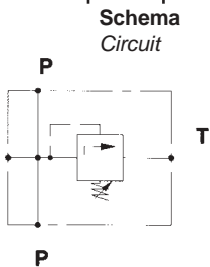

Curve di apertura
Opening curves
Temp.olio 30°C-
Viscosità 33 Cst/40°C

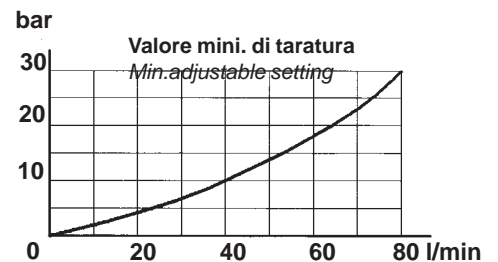

Valore mini. di taratura
Min.adjustable setting