

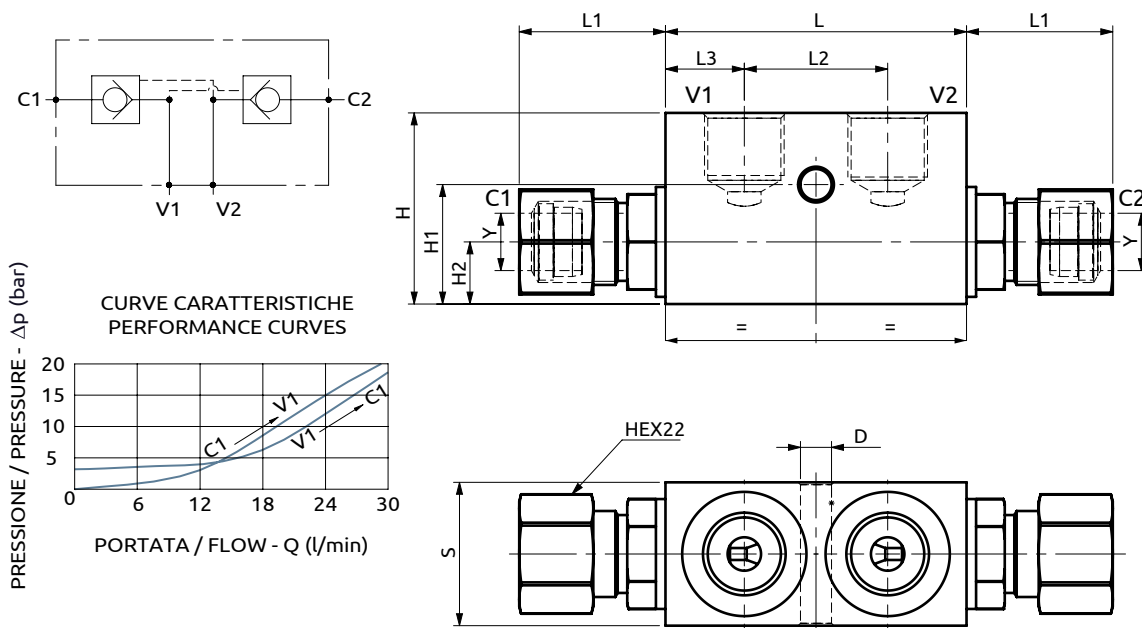

## Valvola di blocco doppia pilotata Dual pilot operated check valve



Corpo in acciaio / Steel body

<b>A050353.16.00</b>	63	30.6	30	16.5	30	40	25	13	Ø6.5	FOR PIPE Ø12
<b>COD.</b>	L	L1	L2	L3	S	H	H1	H2	D	Y



DESCRIZIONE	DESCRIPTION
Permette il flusso libero da A verso C1 e da B verso C2, mentre nelle direzioni inverse il flusso è pilotato. Idonea al sostentamento di un carico, non al controllo discesa.	The valve allows free flow from A to C1 and from B to C2, whereas in the opposite directions the flow is piloted. Suitable to hold a load not to control a load lowering.

Codice Ordinazione	Rapporto di Pilotaggio	Portata Massima	Pressione Max	Pressione di inizio apertura	Dimensione Porte	Peso
Ordering Code	Pilot Ratio	Max Flow	Max Pressure	Cracking Pressure	Port Size	Weight
A050353.16.00	4:1	30 l/min	230 bar	4.5 bar	3/8"G	0.6 kg