

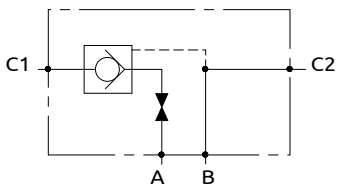

Valvola di blocco semplice pilotata sinistra (con rubinetto)
Single pilot operated check valve with manual shut-off left

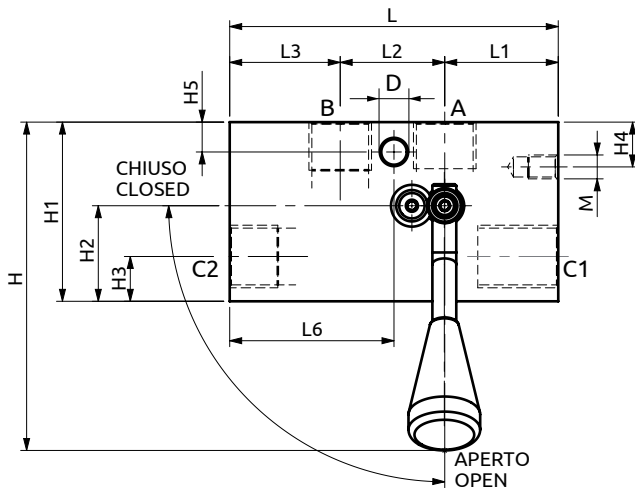

CURVE CARATTERISTICHE
 PERFORMANCE CURVES

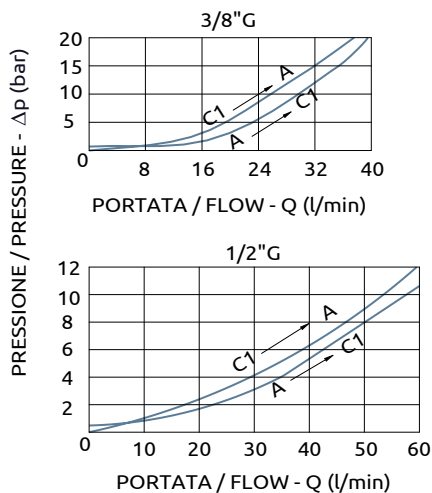

Foro D solo sul cod. A050404.03.00
 D hole only on cod. A050404.03.00

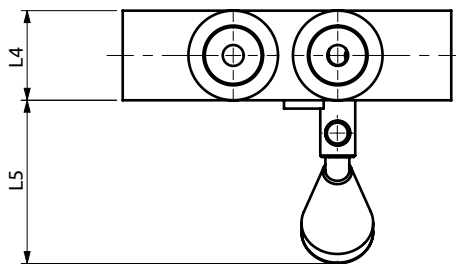

Corpo in acciaio / Steel body

A050304.02.00	82	32	35	15	30	52	-	108	50	27	12	12	-	M8	-
A050404.04.00	110	38	35	37	30	52	55	108	60	30	15	15	10	M8	ø8.5
COD.	L	L1	L2	L3	L4	L5	L6	H	H1	H2	H3	H4	H5	M	D



DESCRIZIONE	DESCRIPTION
Permette il flusso libero da A verso C1. Idonea al sostentamento di un carico, non al controllo discesa.	The valve allows free flow from A to C1. Suitable to hold a load not to control a load lowering.

Codice Ordinazione	Rapporto di Pilotaggio	Portata Massima	Pressione Max	Dimensione Porte	Peso
Ordering Code	Pilot Ratio	Max Flow	Max Pressure	Port Size	Weight
A050304.02.00	4.7:1	40 l/min	400 bar	3/8" G	0.9 kg
A050404.04.00	5.2:1	60 l/min	400 bar	1/2" G	1.4 kg