

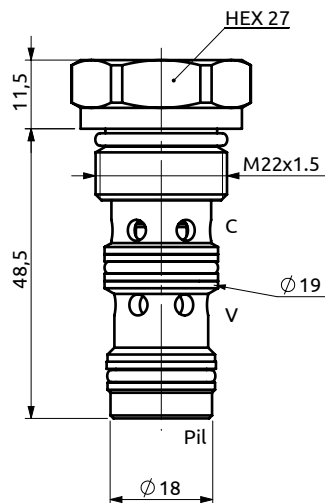

## Valvola di blocco a cartuccia pilotata Pilot operated check valve cartridge type

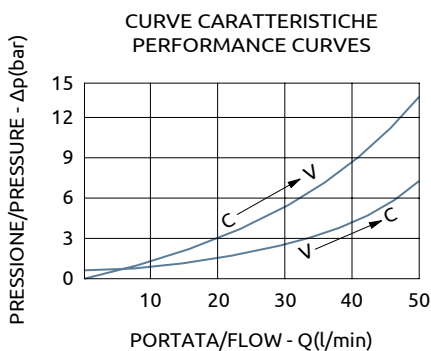
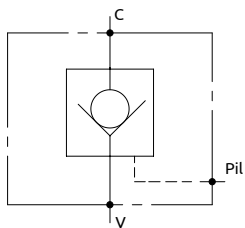

CODICE SEDE

CAVITY CODE

HBS.39.M.03A (Pag. 99.05.01)



DESCRIZIONE

DESCRIPTION

Permette il flusso libero da V verso C. Idonea al sostentamento di un carico, non al controllo discesa.

The valve allows free flow from V to C. Suitable to hold a load not to control a load lowering.

COPPIA DI SERRAGGIO

INSTALLATION TORQUE

60 Nm

Codice Ordinazione	Rapporto di Pilotaggio	Pressione d'inizio Apertura	Portata Massima	Pressione Max	Peso
Ordering Code	Pilot Ratio	Cracking Pressure	Max Flow	Max Pressure	Weight
A053908.01.00	3:1	0.5 bar	50 l/min	350 bar	0.12 kg