

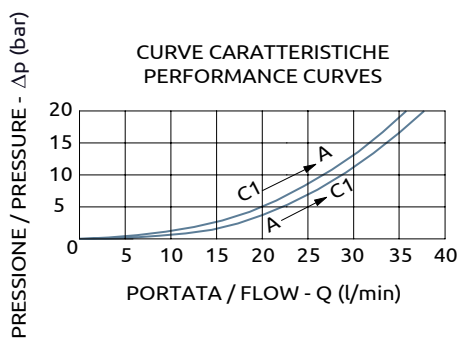

Valvola di blocco semplice pilotata con bullone

Single pilot operated check valve with hollow screw

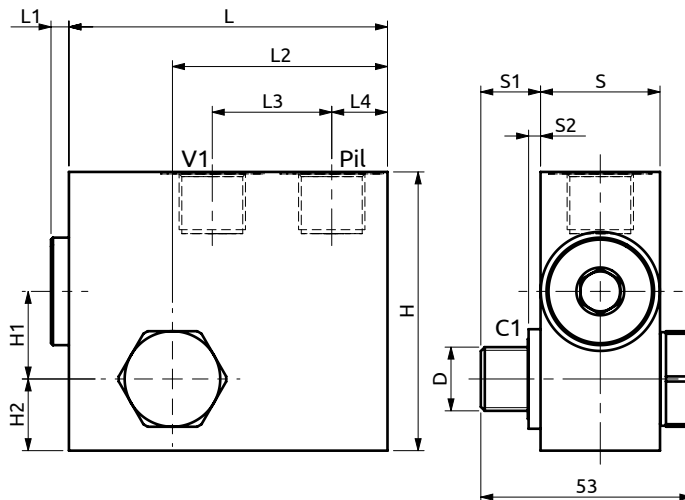
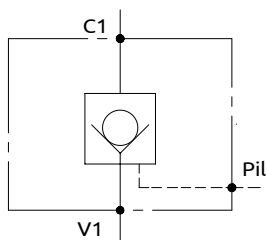

Corpo in alluminio / Aluminium body

80	5	54	30	14	30	15	3	53	70	22	18	M16x1.5
L	L1	L2	L3	L4	S	S1	S2	S3	H	H1	H2	D



DESCRIZIONE

Permette il flusso libero da A verso C1. Idonea al sostentamento di un carico, non al controllo discesa. Le versioni B050310.03.00 e B050310.04.00 non hanno la guarnizione sul pistone di pilotaggio.

DESCRIPTION

The valve allows free flow from A to C1. Suitable to hold a load not to control a load lowering. B050310.03.00 and B050310.04.00 versions do not have the o-ring seal on the piston piloting.

Codice Ordinazione	Rapporto di Pilotaggio	Portata Massima	Pressione d'inizio apertura	Pressione Max	Dimensione Porte	Peso
Ordering Code	Pilot Ratio	Max Flow	Cracking Pressure	Max Pressure	Port Size	Weight
B050310.01.00	4.7:1	40 l/min	0.5 bar	400 bar	3/8"G	0.5 kg
B050310.02.00	4.7:1	40 l/min	7 bar	400 bar	3/8"G	0.5 kg
B050310.03.00	4.7:1	40 l/min	0.5 bar	400 bar	3/8"G	0.5 kg
B050310.04.00	4.7:1	40 l/min	7 bar	400 bar	3/8"G	0.5 kg