

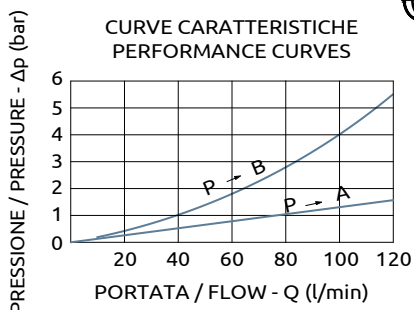

Blocco integrato con deviatore 4 vie, 2 posizioni, regolatore di portata e limitatrice di pressione

4-way, 2-position integrated block with flow control and relief function

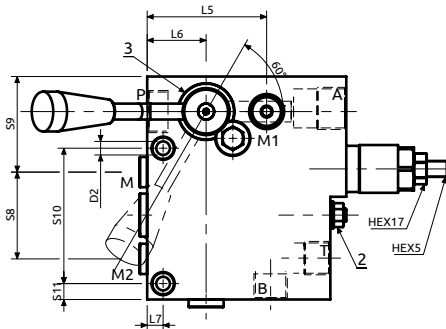
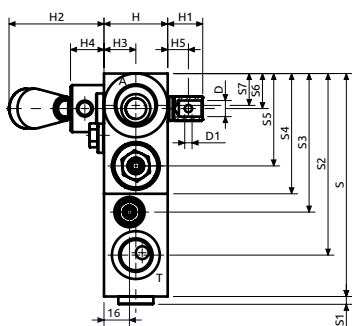
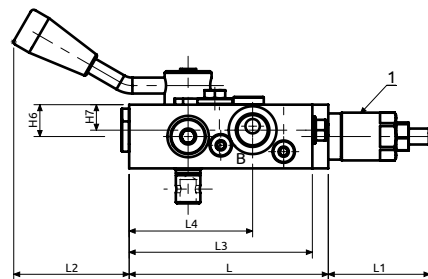
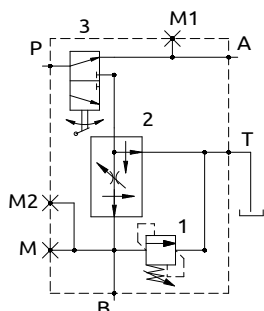

Corpo in acciaio / Steel body

125	~64	~56	115	77.5	75	37	10	140	5	114	87	75.5	58	22	20	54.5	60	85	10	40	22	~66.5	20	21	13	20	16	Ø10	Ø4.5	Ø8.5
L	L1	L2	L3	L4	L5	L6	L7	S	S1	S2	S3	S4	S5	S6	S7	S8	S9	S10	S11	H	H1	H2	H3	H4	H5	H6	H7	D	D1	D2



DESCRIZIONE	DESCRIPTION
La portata regolata sul ramo B resta costante al variare della pressione di lavoro.	The flow on port B can be regulated regardless of the working pressure.
CODICE ORDINAZIONE PIOMBATURA	SEALING ORDERING CODE
916005	

Codice Ordinazione	Campo di Taratura	Taratura Standard	Incremento per giro	Portata Massima	Pressione Max	Dimensione Porte		Peso
Ordering Code	Pressure Range	Standard Setting	Pressure Increase	Max Flow	Max Pressure	Port Size		Weight
A600050.22.00	40-200 bar	200 bar	50 bar/turn	120 l/min	400 bar	P, A	3/4" G	5 kg
						B, T	1/2" G	
						M, M1, M2	1/4" G	