

MODEL  
CKIB

Pilot-to-open check valve with standard pilot  
CAPACITY: 480 L/min. | CAVITY: T-19A

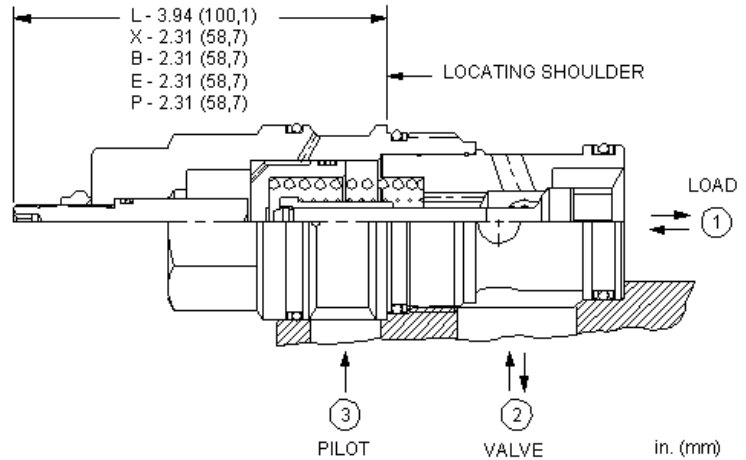
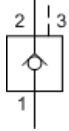

**CONFIGURATION**

<b>X</b>	Control	Standard Pilot
<b>C</b>	Cracking Pressure	30 psi (2 bar)
<b>N</b>	Seal Material	Buna-N
<b>(none)</b>	Material/Coating	Standard Material/Coating

This valve is a pilot to open check valve. It has a non-sealed pilot, a steel seat, and is non-vented. It allows free flow from the valve (port 2) to the load (port 1) and blocks flow in the opposite direction. Pressure at the pilot (port 3) will open the valve from port 1 to port 2. Pilot pressure needed at port 3 to open the valve is directly proportional to the load pressure at port 1. Pressure at port 2 directly opposes pilot pressure.

**TECHNICAL DATA**

Cavity	T-19A
Series	4
Capacity	480 L/min.
Pilot Ratio	3:1
Maximum Operating Pressure	350 bar
Maximum Valve Leakage at 110 SUS (24 cSt)	0,07 cc/min.
Valve Hex Size	41,3 mm
Valve Installation Torque	475 - 508 Nm
Seal kit - Cartridge	Buna: 990-019-007
Seal kit - Cartridge	Polyurethane: 990-019-002
Seal kit - Cartridge	Viton: 990-019-006
Model Weight	1.20 kg.

**SYMBOLS**

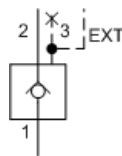
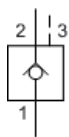

**TECHNICAL FEATURES**

- Provides hose break protection, prevents loads from drifting and positively locks pressurized loads.
- Standard unsealed pilot allows air trapped in the pilot line to be purged from the circuit.
- Extremely low leakage. The seat and poppet are heat treated for long life. If the load drifts due to the valve, the seat has probably been damaged by contamination and the valve should be replaced.
- Optional external porting out of the hex end of the cartridge is available for external piloting. In this configuration, port 3 is blocked. See Control options E, and P.
- Pilot-to-open check cartridges are locking valves, not motion control valves. For motion control applications, use counterbalance valves.
- For models with manual load release control option, turn load release clockwise to release load.
- This 3 port pilot-to-open check valve and 3 port counterbalance valves are physically interchangeable (i.e. same cavities, same flow path for a given frame size). However, cartridge extension dimensions from the mounting surface may vary.
- Corrosion resistant cartridge valves are intended for use in corrosive environments and are identified by the model code suffix /AP for external stainless steel components, or /LH for external zinc-nickel plated components. See the CONFIGURATION section for all options. For further details, please see the Materials of Construction page located under TECH RESOURCES.
- Incorporates the Sun floating style construction to minimize the possibility of internal parts binding due to excessive installation torque and/or cavity/cartridge machining variations.

## PERFORMANCE CURVES

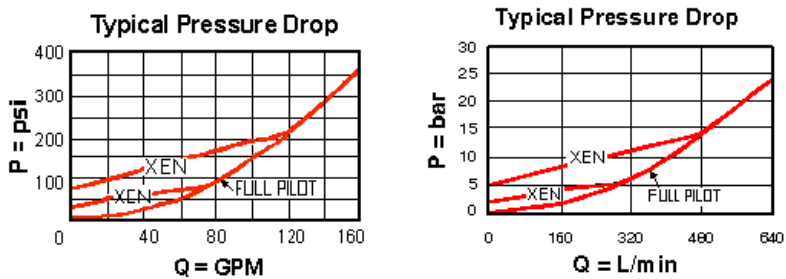

## CONFIGURATION OPTIONS

### CONTROL

Preferred Options	X	Standard Pilot
Standard Options	L	Manual Load Release

### CRACKING PRESSURE

Preferred Options	C	30 psi (2 bar)
	A	4 psi (0,3 bar)
	B	15 psi (1 bar)
Standard Options	D	50 psi (3,5 bar)
	E	75 psi (5 bar)
	F	100 psi (7 bar)

### SEAL MATERIAL

Preferred Options	N	Buna-N
Standard Options	V	Viton

### MATERIAL/COATING

Standard Options		Standard Material/Coating
	/AP	Stainless Steel, Passivated

Copyright © 2002-2014 Sun Hydraulics Corporation. All rights reserved.