

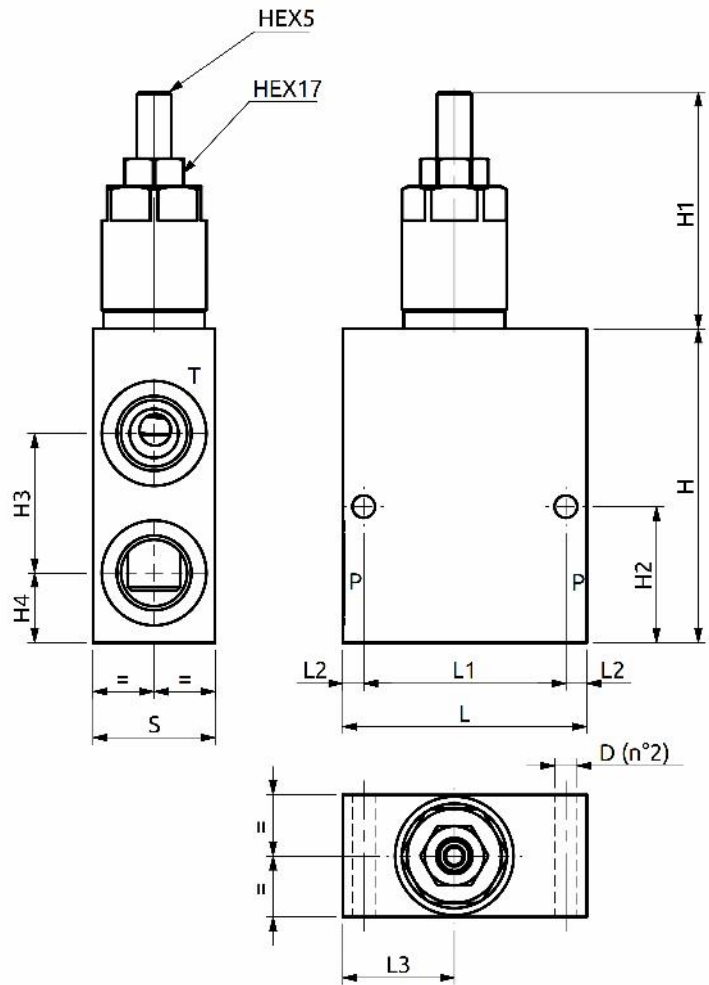

Valvola limitatrice di pressione
Relief valve

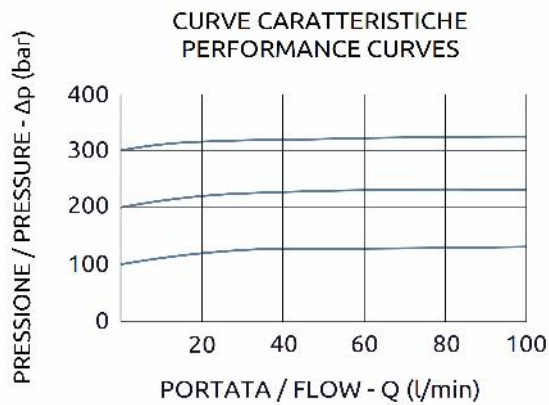
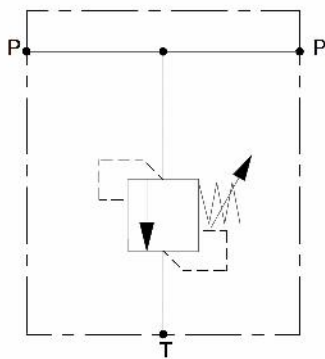

Corpo in acciaio / Steel body

A010401.05.00	70	58	6	32	35	90	66.5 max	39	40	20	Ø6.5
A010601.04.00	70	54	8	32	40	90	67 max	45	50	20	Ø8.5
COD.	L	L1	L2	L3	S	H	H1	H2	H3	H4	D



DESCRIZIONE	DESCRIPTION
Valvola limitatrice di pressione con tenuta a cono, con funzione di protezione del circuito da sovrappressioni.	Relief valve in compact steel construction poppet type, for overload protection.

CODICE ORDINAZIONE PIOMBATURA	SEALING ORDERING CODE
916003-916005	

Codice Ordine	Campo di Taratura	Taratura Standard	Incremento per Giro	Portata Massima	Pressione Max	Dimensione Porte	Peso
Ordering Code	Pressure Range	Standard Setting	Pressure Increase	Max Flow	Max Pressure	Port Size	Weight
A010401.05.00	100-300 bar	200 bar	75 bar/turn	70 l/min	350 bar	1/2"G	1.6 kg
A010601.04.00	150-380 bar	200 bar	75 bar/turn	100 l/min	400 bar	3/4"G	1.7 kg