

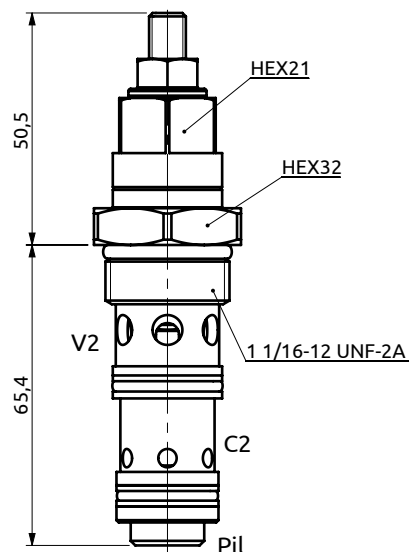

Valvola di bilanciamento semplice effetto, serie 165 Single overcenter "165 series"

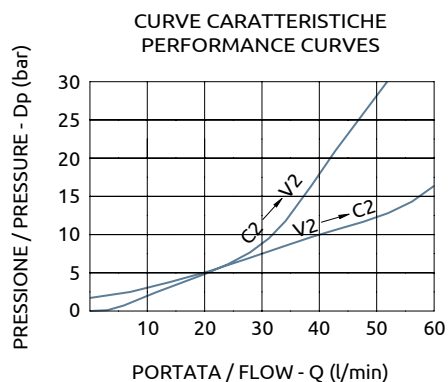

CODICE SEDE	CAVITY CODE
HBS.96.S.03A (Pag. 99.08.01)	

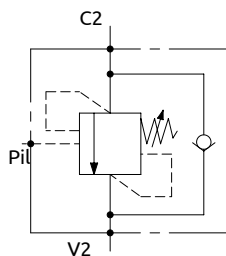

DESCRIZIONE

Valvola di bilanciamento a semplice effetto, consigliata per distributori con spole a centro aperto in neutro. Collegare all'impianto come da schema. La valvola permette: flusso libero da V2 verso C1, sostentamento del carico con distributore in neutro o a pompa ferma, controllo del movimento di discesa del carico a seguito del pilotaggio della valvola pilotaggio, protezione da sovrappressioni nel cilindro.

DESCRIPTION

Single overcenter valve, suggested for use with open centre spools. To be connected as shown. The valve allows: free flow from V2 to C1, to hold the load with spool in neutral position or with the pump not running, controlled movement when pilot pressure is applied, relief function against overpressure in the cylinder.

COPPIA DI SERRAGGIO

INSTALLATION TORQUE

120 Nm

Codice Ordinazione	Rapporto di Pilotaggio	Campo di Taratura	Taratura Standard	Incremento per Giro	Portata Massima	Pressione Max	Peso
Ordering Code	Pilot Ratio	Pressure Range	Standard Setting	Pressure Increase	Max Flow	Max Pressure	Weight
C069601.01.00	4.25:1	100-350 bar	350 bar	135 bar/turn	60 l/min	400 bar	0.28 kg