

A-VBSO-DE-30-CSL-FC1

08.44.30 - X - Y - Z

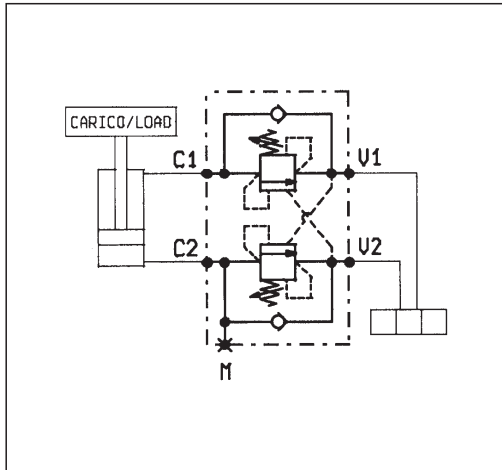
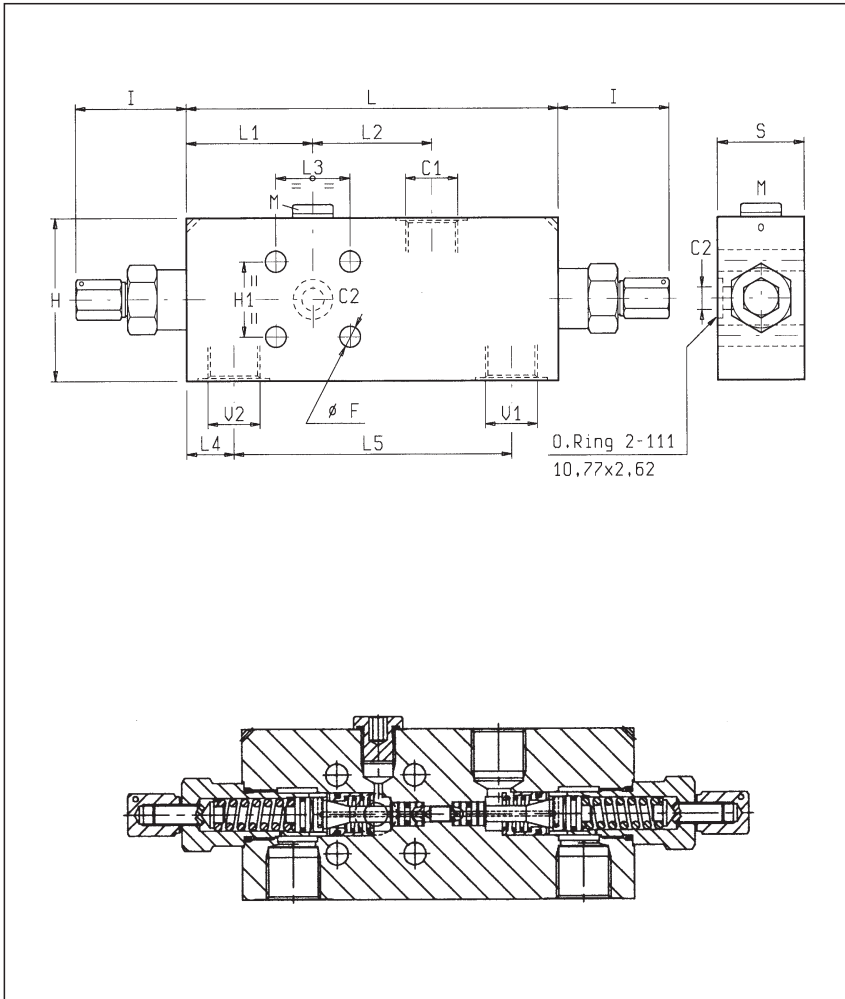

DATI TECNICI / TECHNICAL DATA	
Pressione max. Max. pressure	350 bar
Portata max. Flow max.	60 l/min
Taratura della valvola: almeno 1.3 volte superiore alla pressione indotta dal carico Pressure setting: at least 1.3 times the load induced pressure	
Con fori per piombatura a filo With holes for wire-locking	
Collettore in acciaio Steel body	

34.5	30	65	45	112	19.5	30	47	52	151	8.5							1/2	2.2	
29.5	30	55	45	112	19.5	30	48	51.5	151	8.5								3/8	1.7
S	H1	H	I	L5	L4	L3	L2	L1	L	F							Y	Peso kg Weight kg	

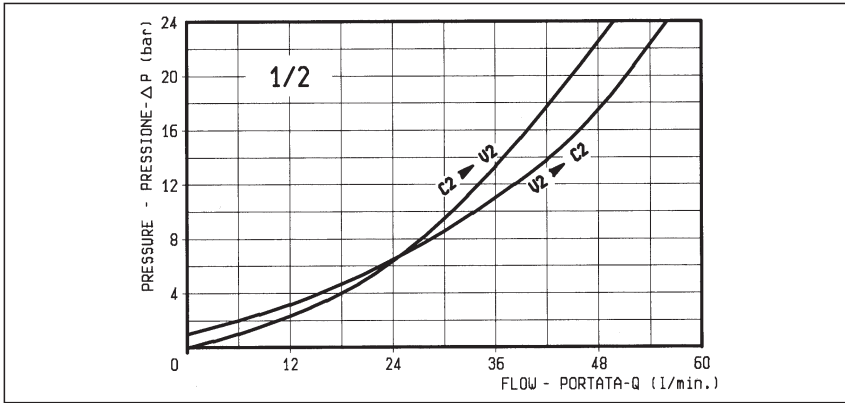

X	RAPPORTO DI PILOTAGGIO PILOT RATIO
03	4.2 : 1

Z	MOLLE / SPRINGS				
	Campo taratura min - max bar Adj. press. range bar	Incremento press. bar / giro vite Press. increase bar / turn	Taratura standard bar (Q = 5 l/min) Std. setting bar (made at = 5 l/min)	Cod. ordinazione Ordering code	Colore Colour
35	100-350	138	350	03.51.01.171	giallo yellow

Y	ATTACCHI / PORT SIZE		
	V1-V2-C1	C2	M
02	G 3/8	Ø 9	G 1/4
03	G 1/2	Ø 9	G 1/4