

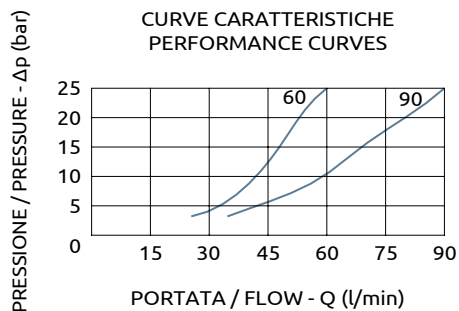

Divisore e riunificatore di flusso a cartuccia Flow dividers/combiners cartridge type

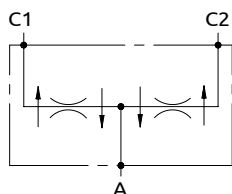

CODICE SEDE	CAVITY CODE
HBS.96.U.04A	(Pag. 99.03.00)

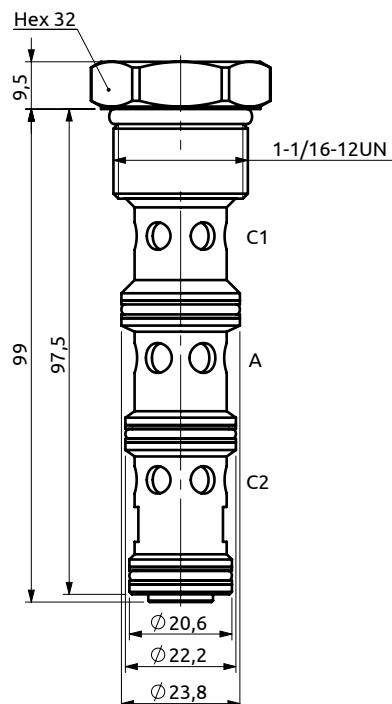

DESCRIZIONE	DESCRIPTION
Le valvole permettono di dividere il flusso d'olio in ingresso in due portate uguali, indipendentemente dalle pressioni di lavoro sui due rami. Nel verso opposto mantengono uguali le portate riunificate.	These valves split the inlet flow in two equal parts and keep equal the flows in the reverse direction, regardless of the working pressure on both lines.
COPPIA DI SERRAGGIO	INSTALLATION TORQUE
40 Nm	

Codice Ordinazione	Rapporto di Divisione	Portata Massima all'ingresso	Pressione Max	Peso
Ordering Code	Flow Division Ratio	Max Inlet Flow	Max Pressure	Weight
C149600.01.00	50:50	60 l/min	240 bar	0.3 kg
C149600.02.00	50:50	90 l/min	240 bar	0.3 kg