

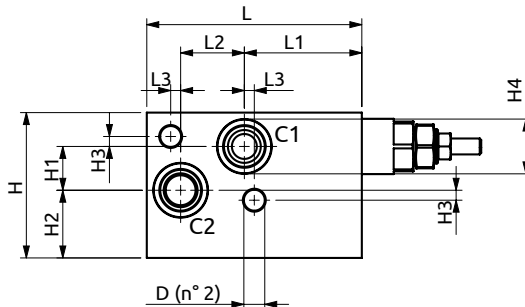

Valvola di bilanciamento semplice effetto flangiabile con cartuccia serie SM  
*Flangeable single overcenter valve with cartridge "SM series"*

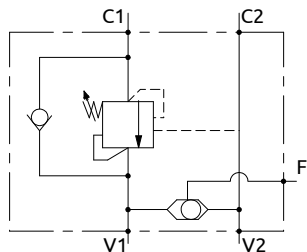

PRESSIONE / PRESSURE - Δp (bar)

CURVE CARATTERISTICHE  
 PERFORMANCE CURVES

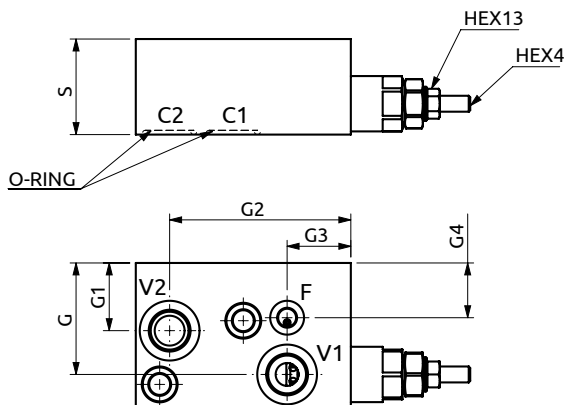
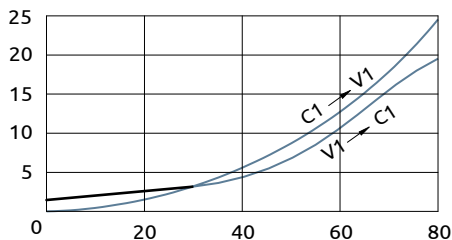

Corpo in alluminio / Aluminium body

<b>B060481.02.00</b>	108	59	32	5	48	73	22	34	5	27.5	56	34	91	32	27.5	Ø10.5	OR 130	22.22x2.62
<b>COD.</b>	L	L1	L2	L3	S	H	H1	H2	H3	H4	G	G1	G2	G3	G4	D	O-RING	



DESCRIZIONE	DESCRIPTION
Valvola di blocco bilanciata semplice con flangiatura per motori DANFOSS OMS.	Single flangeable overcenter valve for DANFOSS motors OMS.
CODICE ORDINAZIONE PIOMBATURA	SEALING ORDERING CODE
916005	

Codice Ordinazione	Rapporto di Pilotaggio	Campo di Taratura	Taratura Standard	Incremento per giro	Portata Massima	Pressione Max	Dimensione Porte		Peso
Ordering Code	Pilot Ratio	Pressure Range	Standard Setting	Pressure Increase	Max Flow	Max Pressure	Port Size		Weight
B060481.02.00	4.25:1	100-350 bar	210 bar	106 bar/turn	80 l/min	350 bar	V1-V2	1/2"G	1.15 kg
							F	M10x1	