

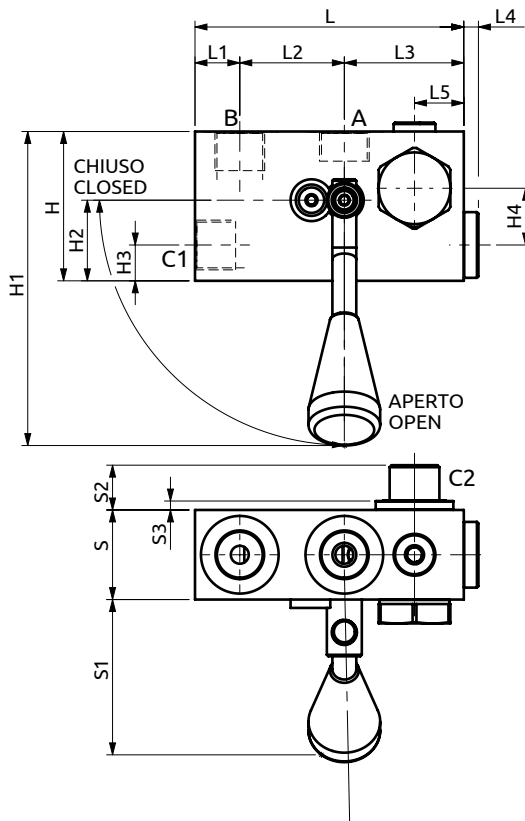

Valvola di blocco semplice pilotata sinistra (con rubinetto) flangiata con bullone  
*Single pilot operated fangeable check valve with manual shut-off left*

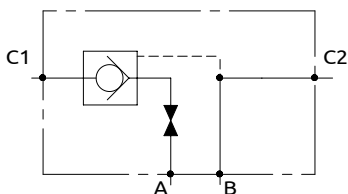

CURVE CARATTERISTICHE  
 PERFORMANCE CURVES

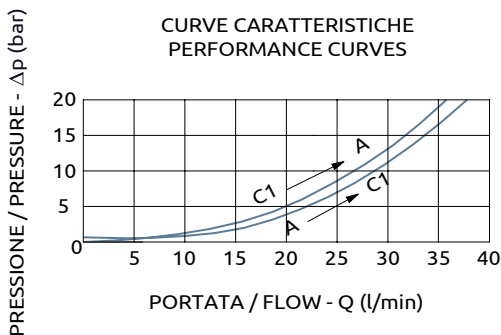

Corpo in acciaio / Steel body

<b>A050302.02.00</b>	90	15	35	40	5	16.5	30	52	15	3	50	108	27	12	19
<b>COD.</b>	L	L1	L2	L3	L4	L5	S	S1	S2	S3	H	H1	H2	H3	H4



DESCRIZIONE	DESCRIPTION
Permette il flusso libero da A verso C1. Idonea al sostentamento di un carico, non al controllo discesa.	The valve allows free flow from A to C1. Suitable to hold a load not to control a load lowering.

Codice Ordine	Rapporto di Pilotaggio	Portata Massima	Pressione Max	Dimensione Porte	Peso
Ordering Code	Pilot Ratio	Max Flow	Max Pressure	Port Size	Weight
A050302.02.00	4.7:1	40 l/min	400 bar	3/8"G	1 kg