

MODEL
CBCAX

Fixed setting, 3:1 pilot ratio, standard capacity counterbalance valve
CAPACITY: 60 L/min. | **CAVITY:** T-11A

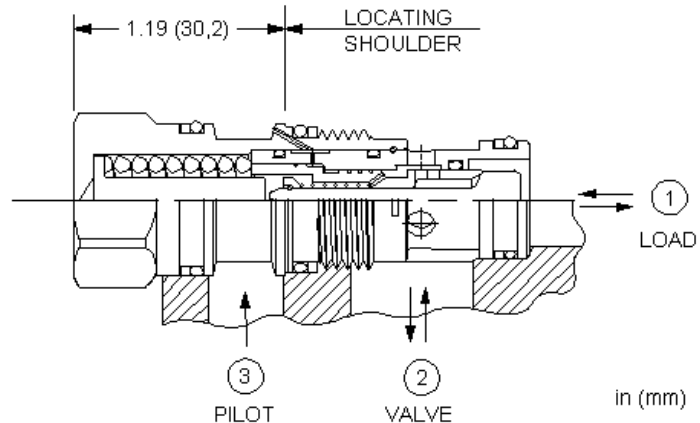
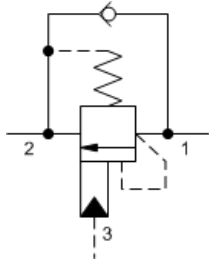

CONFIGURATION

N	Fixed Pressure Range	2900 - 3500 psi (200 - 245 bar)
N	Seal Material	Buna-N
(none)	Material/Coating	Standard Material/Coating

Fixed-setting, 3-port counterbalance valves with pilot assist function similarly to the adjustable versions except the fixed setting is pre-set to a nominal value. These fixed-setting valves are meant to control an overrunning load. The check valve allows free flow from the directional valve (port 2) to the load (port 1) while a direct-acting, pilot-assisted relief valve controls flow from port 1 to port 2. Pilot assist at port 3 lowers the effective setting of the relief valve at a rate determined by the pilot ratio.

Other names for this valve include motion control valve and over center valve.

TECHNICAL DATA

Cavity	T-11A
Series	1
Capacity	60 L/min.
Pilot Ratio	3:1
Factory Pressure Settings Established at	30 cc/min.
Maximum Valve Leakage at Reseat	0,3 cc/min.
Check Cracking Pressure	1,7 bar
Operating Characteristic	Standard
Valve Hex Size	22,2 mm
Valve Installation Torque	41 - 47 Nm
Seal kit - Cartridge	Buna: 990-011-007
Seal kit - Cartridge	Polyurethane: 990-011-002
Seal kit - Cartridge	Viton: 990-011-006
Model Weight	0.12 kg.

TECHNICAL FEATURES

- The maximum recommended load pressure for the N range is 2200 psi (150 bar). The highest cracking pressure for the N range will be less than 3500 psi (245 bar).
- The maximum recommended load pressure for the P range is 1700 psi (120 bar). The highest cracking pressure for the P range will be less than 2680 psi (185 bar).
- Note: The pressures listed under RANGE are approximate, mean values and should not be used for inspection purposes.
- Note: The percentage difference between the cracking and reseat values for the fixed and adjustable versions of this valve are identical. However, the cracking point for the adjustable control can be set via the adjustment mechanism to within +/- 50 psi (3,5 bar) of the specified value. In the case of the fixed-setting version, the setting tolerance can only be maintained within a several hundred psi span, depending on the range. The maximum recommended load pressure for any given range is the minimum possible setting divided by 1.3.
- Fixed-setting counterbalance valves offer a shorter cartridge extension than the adjustable version.

- Fixed-setting counterbalance valves can be used to protect cylinder seals in outrigger circuits from damage due to thermal expansion, however, they probably should not be applied in circuits in which a matched valve setting may be required such as dual cylinder applications.
- This valve does not have positive seals on the pilot section and will pass up to 2 in³/min.@1000 psi (32 cc/min.@70 bar) between port 2 and port 3. This is a consideration in master-slave circuits and in the leak testing of valve-cylinder assemblies.
- Backpressure at port 2 adds to the effective relief setting at a ratio of 1 plus the pilot ratio times the backpressure.
- All 3-port counterbalance, load control, and pilot-to-open check cartridges are physically interchangeable (i.e. same flow path, same cavity for a given frame size).
- Incorporates the Sun floating style construction to minimize the possibility of internal parts binding due to excessive installation torque and/or cavity/cartridge machining variations.

PERFORMANCE CURVES

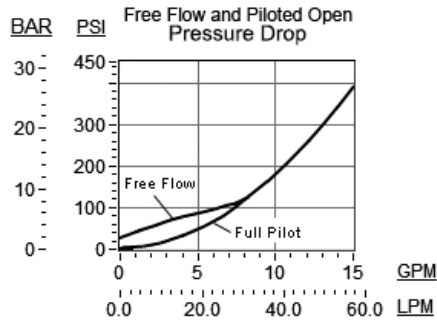

CONFIGURATION OPTIONS

FIXED PRESSURE RANGE

Standard Options	N	2900 - 3500 psi (200 - 245 bar)
	P	2250 - 2680 psi (155 - 185 bar)

SEAL MATERIAL

Standard Options	N	Buna-N
	V	Viton

MATERIAL/COATING

Standard Options		Standard Material/Coating
	/AP	Stainless Steel, Passivated
	/LH	Mild Steel, Zinc-Nickel

RELATED MODELS

CBCA

3:1 pilot ratio, standard capacity counterbalance valve

Copyright © 2002-2014 Sun Hydraulics Corporation. All rights reserved.