

### DATA SHEET - OPERATION MANUAL

#### APPLICATION

Directional spool valves type **WEH16...** electro-hydraulically operated are intended for change in direction of fluid flow in a system and thus it allows to change direction of movement of a receiver - mostly piston rod of a cylinder or hydraulic motor as well to use functions: *on* and *off*. These directional spool valves are used for subplate mounting in any position in a hydraulic system.

The directional spool valve type **WEH16...** is complied with the regulations of directive **2006/95/WE** for the following voltages:

- 50 - 250 V for AC
- 75 - 250 V for DC

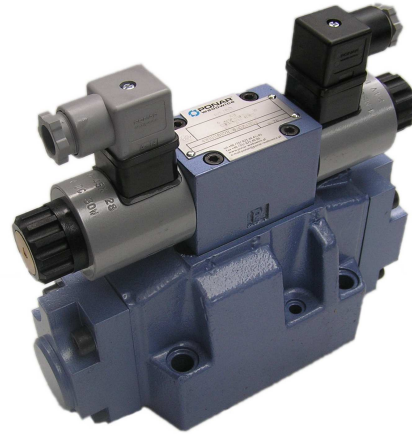

#### DESCRIPTION OF OPERATION

H-4WEH16E73/G24NZ4

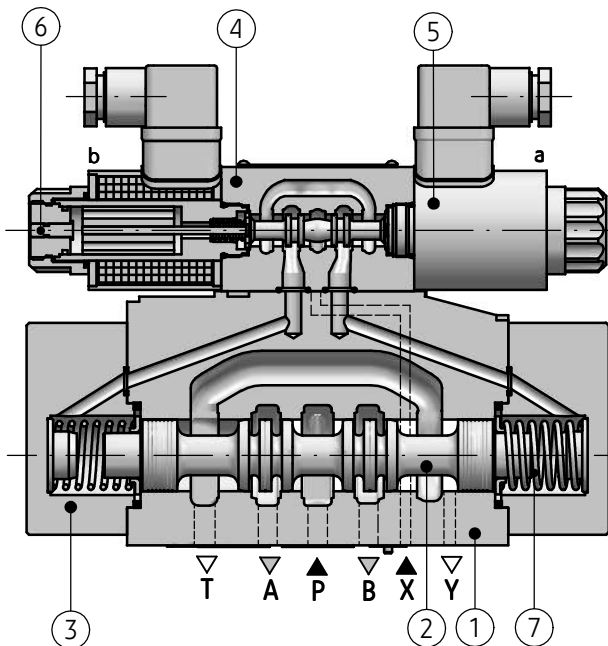

H-4WEH16HE73/G24NZ4

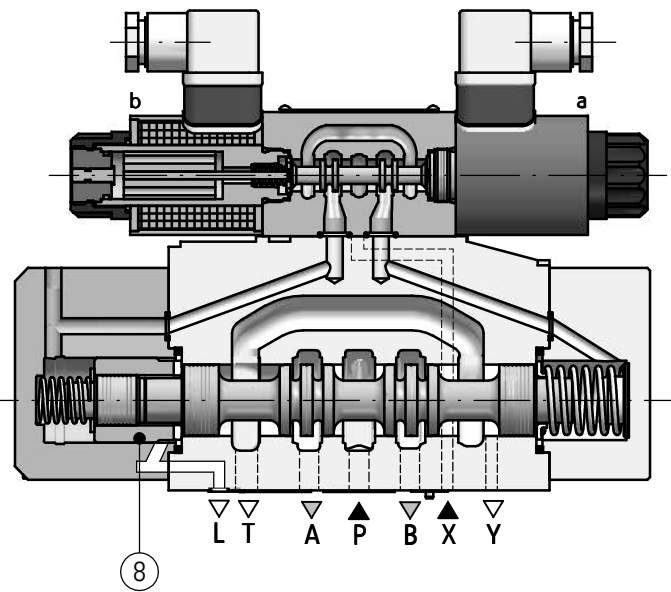

Main bore and annular ports **P, T, A, B** are made in the housing (1) and connected to its subplate connection. Directional valve is switched by shifting the spool (2) into one end position. Various control functions are dependent on the spool (2) which affects the change in configuration of connections among ports **P, T, A, B** in the housing (1). The spool (2) is shifted from its neutral position by affecting pressure of hydraulic fluid supplied via pilot valve (4) into one chamber of caps (3). The pilot valve (4) - type **WE6...** is operated by means of

solenoids (5). In case of failure, the pilot valve (4) may be shifted manually by means of manual overrides (6) - version ...4WEH16.../...N. The spool (2) is centered in neutral position by means of springs (7) - version ...4WEH16.../... or may be hydraulically operated by the fluid pressure from the pilot valve (4) - version ...4WEH16H.../... - for 3-position directional valves the centering is possible by means of the sleeve (8).

## DESCRIPTION OF OPERATION

...WEH16.../...S...

...WEH16.../...M...

...WEH16.../...11...

...WEH16.../...18...

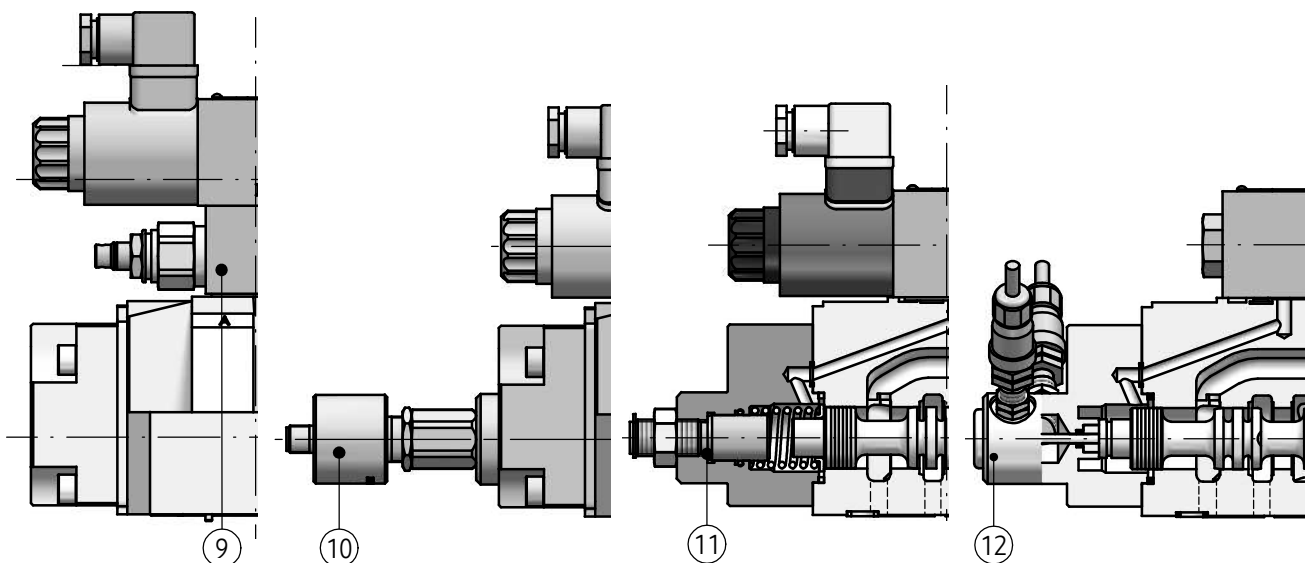

Directional spool valves may be provided with the pilot choke adjustment (9) as well as with accessories such as: spool position sensor (10), spool stroke

limiter (11), spool end position monitor (12). Accessories may be mounted depending on version of directional valve like given on pages 14 - 25.

## TECHNICAL DATA

<b>Hydraulic fluid</b>	
Hydraulic fluid	mineral oil
<b>Required fluid cleanliness class</b>	<b>ISO 4406 class 20/18/15</b>
Nominal fluid viscosity	37 mm <sup>2</sup> /s at temperature 55 °C
Viscosity range	2,8 up to 380 mm <sup>2</sup> /s
Fluid temperature range (in a tank)	recommended 40 °C up to 55 °C
Ambient temperature range	max -20 °C up to +70 °C - 20 °C up to +50 °C
<b>Max operating pressure</b>	
<u>Ports A, B, P</u>	
• version H-4 WEH 16.../...	<b>35 MPa</b>
• version 4 WEH 16.../...	<b>28 MPa</b>
<u>Port T</u>	
• pilot fluid return Y- external	<b>25 MPa</b>
• pilot fluid return Y- internal (2-position and 3-position directional valve spring centered only, no 3-position version hydraulically centered with Y- internal	<b>21 MPa</b>
<b>Max control pressure</b>	<b>25 MPa</b>
<b>Min control pressure</b>	
<u>Pilot fluid supply X- external</u>	
• 3-position directional valve	0,8 MPa
• 2-position directional valve spring positioned	1,0 MPa
• 2-position directional valve hydraulically positioned	0,5 MPa
<u>Pilot fluid supply X- internal</u> (when pre-load valve applied or when flow rate is suitably high)	
• versions 4 WEH 16... with spools G,H,F,S,T	0,45 MPa
• versions H-4 WEH 16.../...D1... with spools G,H,F,S,T	0,7 MPa

## TECHNICAL DATA

<b>Fluid volume required to operate the valve</b>	
<u>3-position spring centered directional valve</u>	5,75 cm <sup>3</sup>
<u>3-position hydraulically centered directional valve</u>	
• from 0 (neutral) to operated position <i>a</i>	2,85 cm <sup>3</sup>
• from 0 (neutral) to operated position <i>b</i>	5,75 cm <sup>3</sup>
• from operated position <i>a</i> to 0 (neutral) position	2,9 cm <sup>3</sup>
• from operated position <i>b</i> to 0 (neutral) position	2,3 cm <sup>3</sup>
<u>2-position directional spool valve</u>	11,5 cm <sup>3</sup>
<b>Total time of spool shifting from neutral to end position</b>	
<u>3-position spring centered directional valve</u>	
at pilot pressure	
p st = 5 MPa	50 ms
p st = 15 MPa	45 ms
p st = 25 MPa	40 ms
<u>3-position hydraulically centered directional valve</u>	
• solenoid <i>a</i> operation	
at pilot pressure	
p st = 5 MPa	40 ms
p st = 15 MPa	40 ms
p st = 25 MPa	40 ms
• solenoid <i>b</i> operation	
at pilot pressure	
p st = 5 MPa	50 ms
p st = 15 MPa	45 ms
p st = 25 MPa	40 ms
<u>2-position directional valve</u>	
at pilot pressure	
p st = 5 MPa	55 ms
p st = 15 MPa	50 ms
p st = 25 MPa	45 ms
<b>Total time of spool shifting from end to neutral position</b>	
<u>3-position spring centered directional valve</u>	
at pilot pressure	
p st = 5; 15; 25 MPa	40 ms
<u>3-position hydraulically centered directional valve</u>	
• solenoid <i>a</i> operation	
at pilot pressure	
p st = 5 MPa	30 ms
p st = 15 MPa	25 ms
p st = 25 MPa	20 ms
• solenoid <i>b</i> operation	
at pilot pressure	
p st = 5 MPa	40 ms
p st = 15 MPa	35 ms
p st = 25 MPa	30 ms
<u>2-position directional valve</u>	
at pilot pressure	
p st = 5 MPa	35 ms
p st = 15 MPa	30 ms
p st = 25 MPa	25 ms

## TECHNICAL DATA

<b>Pilot valve</b>							
Type of pilot valve							
• for 3-position spring centered main directional valve		4WE6 J...					
• for 2-position spring centered main directional valve (a, 0)		4WE6 JA...					
• for 2-position spring centered main directional valve (0, b)		4WE6 JB...					
• for 3-position hydraulically centered main directional valve		4WE6 M...					
• for 2-position hydraulically centered main directional valve (a, 0)		4WE6 MA...					
• for 2-position hydraulically centered main directional valve (0, b)		4WE6 MB...					
• for 2-position main directional valve		4WE6 D... or 4WE6 D... /O... or 4WE6 D... /OF...					
<b>Supply voltage of solenoids</b>		<b>DC</b>		<b>AC</b>			<b>AC</b>
				(plug-in connector with rectifier)			direct supply
		12V	24V	110V	230V-50Hz	220V- 50Hz	110V- 50Hz
Supply voltage tolerance		±10%					
Power requirement (DC)		30 W					
<b>Degree of protection</b>		<b>IP 65</b>					
Temperature of solenoid coil		max 150 °C					
<b>Inductive spool position sensors</b>							
<b>Type of sensors</b>		two PNP inductive proximity sensors: normally closed - NC (contact breaker) + normally opened - NO (contact maker)					
<b>Supply voltage</b>		10 - 30V DC					
<b>Max load current</b>		200 mA					
<b>Connection type of sensor</b>		sensor with M12x1 external thread, male connection					
<b>Connection type of conductor</b>		plug with M12 x 1 internal thread, female plug configuration of connection according to PN-EN-61076 -2-101					
<b>External diameter of conductor</b>		φ 2,5 - 6,5 mm (PG7)					
<b>Degree of protection</b>		IP 67					
<b>Weight</b>		max 10,5 kg					

## INSTALLATION AND APPLICATION REQUIREMENTS

1. Only fully functional and operational valve, properly connected to electrical installation must be used. Connecting or disconnecting the valve to an electrical installation must only be carried out by qualified personnel.
2. Ground connection ( $\perp$ ) must be connected with protective earth wire (PE  $\perp$ ) in supply system according to appropriate instructions.
3. Solenoid plug shall precisely adhere to socket and shall be secured with thread bolt screwed in securely in a place. It is forbidden to operate the valve if the tightness and suitable clamp of cable in the plug gland are not ensured.
4. For the ...W230 - 50... pilot valve version, simultaneous joining of two solenoids of the same valve should not be permitted (partial overriding of the valve can overheat and damage the winding coils).
5. During the period of operation must be kept fluid viscosity acc. to requirements defined in this Data Sheet - Operation Manual
6. In order to ensure failure free and safe operation the following must be checked:
  - condition of the electrical connection
  - proper working of the valve
  - cleanliness of the hydraulic fluid
7. Due to heating of electromagnet solenoid coils to high temp., the valve shall be placed in such way to eliminate the risk of accidental contact with solenoid during operation or to apply suitable covers acc. to PN - EN ISO 13732 -1 and PN - EN 982
8. In order to ensure tightness of the directional valve block, one should take care of dimension of sealing rings and valve operation parameters given in this Data Sheet - Operation Manual
9. A person that operates the valve must be thoroughly familiar with this Data Sheet - Operation Manual.

# DIAGRAMS

Simplified and detailed hydraulic diagrams for 3-position directional valves with various pilot supply (X) and pilot drain (Y)

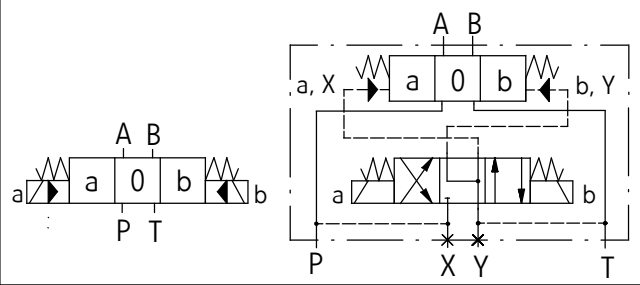
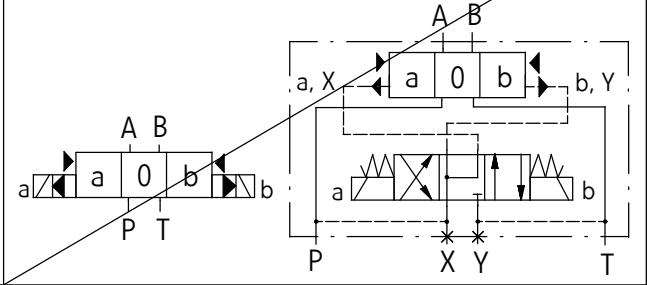
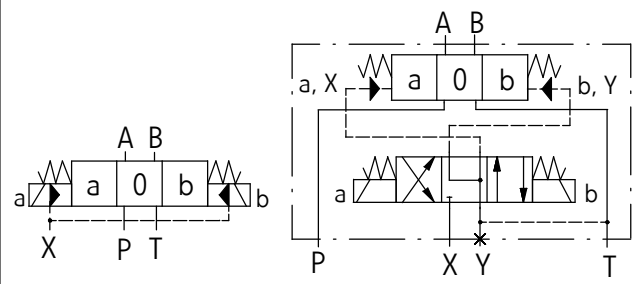
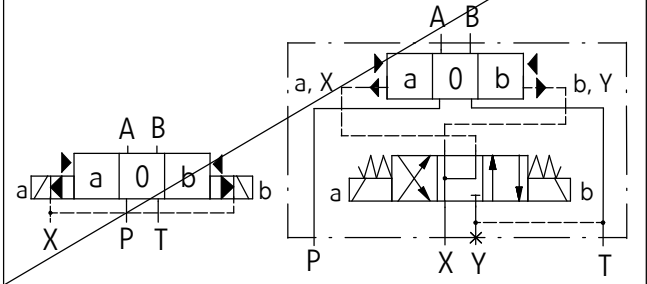
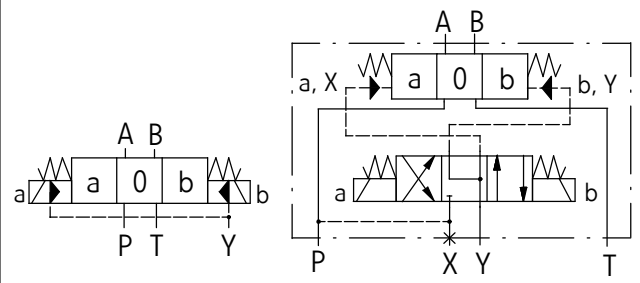
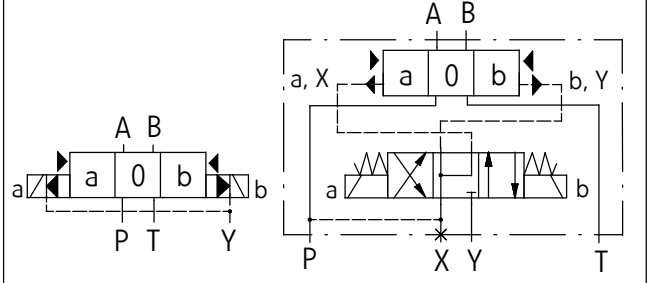
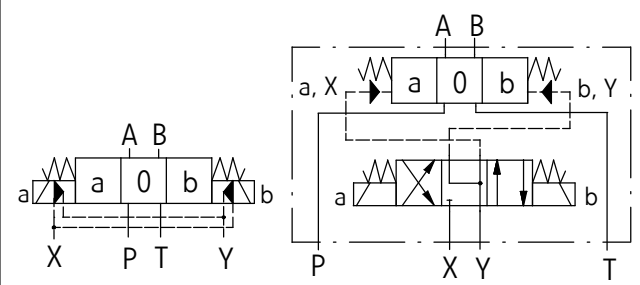
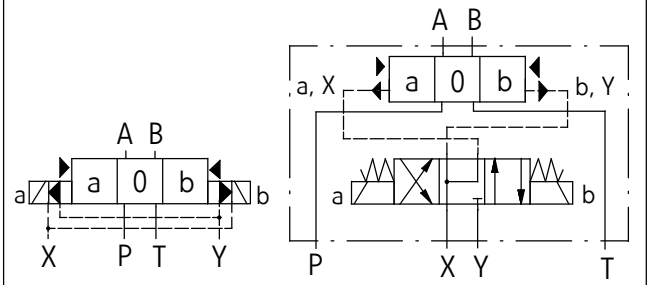
<p>3-position directional valves with spring centered spool at 0 position in main valve and pilot valve version ...4WEH16.../...</p>	<p>3-position directional valves with hydraulically centered spool at 0 position in main valve and spring centered spool in pilot valve version ...4WEH16H.../...</p>
<p><b>internal</b> supply (X); <b>internal</b> drain (Y) version ...4WEH16.../...ET...</p> 	<p><b>internal</b> supply (X); <b>internal</b> drain (Y) version ...4WEH16H.../...ET...- impossible</p> 
<p><b>external</b> supply (X); <b>internal</b> drain (Y) version ...4WEH16.../...T...</p> 	<p><b>external</b> supply (X); <b>internal</b> drain (Y) version ...4WEH16H.../...T...- impossible</p> 
<p><b>internal</b> supply (X); <b>external</b> drain (Y) version ...4WEH16.../...E...</p> 	<p><b>internal</b> supply (X); <b>external</b> drain (Y) version ...4WEH16H.../...E...</p> 
<p><b>external</b> supply (X); <b>external</b> drain (Y) version...4WEH16.../...</p> 	<p><b>external</b> supply (X); <b>external</b> drain (Y) version ...4WEH16H.../...</p> 

# DIAGRAMS

Simplified and detailed hydraulic diagrams for 2-position directional valves with various pilot supply (X) and pilot drain (Y)

2-position directional valves with spring positioned spool in main valve and pilot valve  
version ...4WEH16.../...

2-position directional valves with hydraulically positioned spool in main valve and spring positioned spool in pilot valve  
version ...4WEH16H.../...

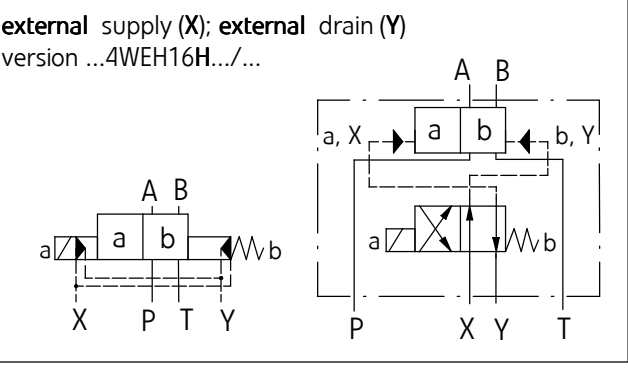
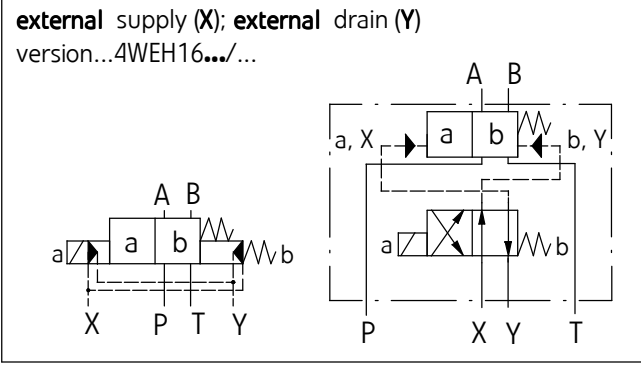
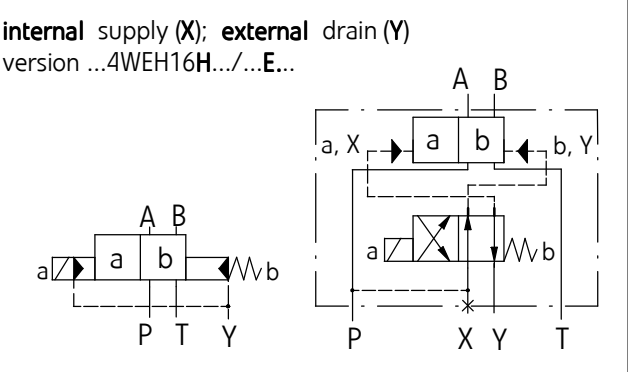
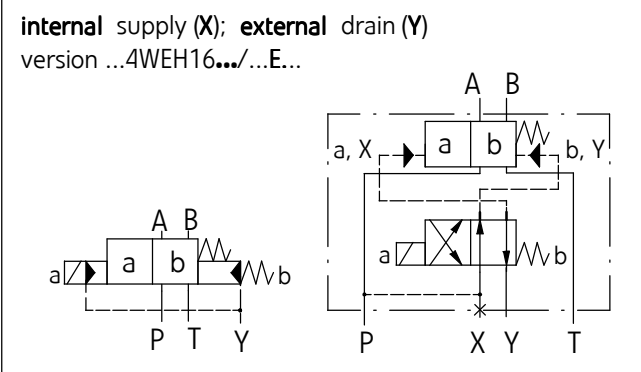
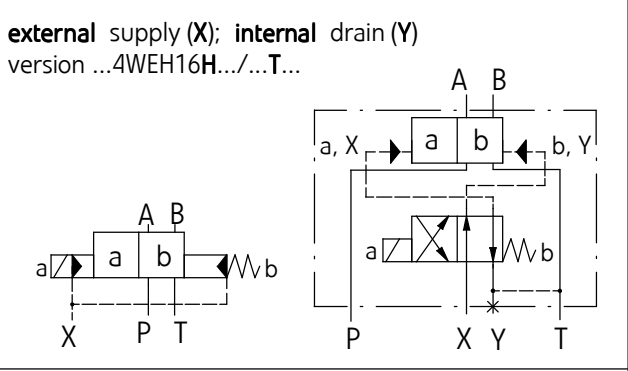
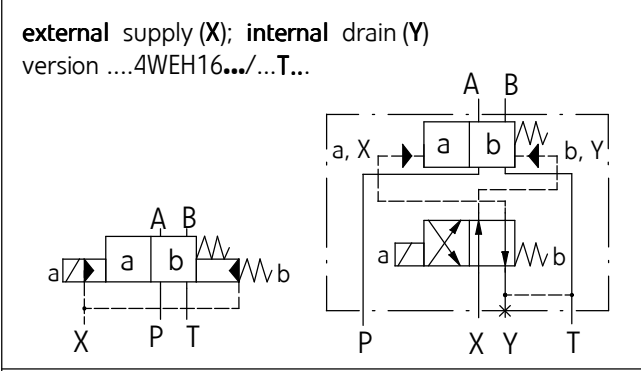
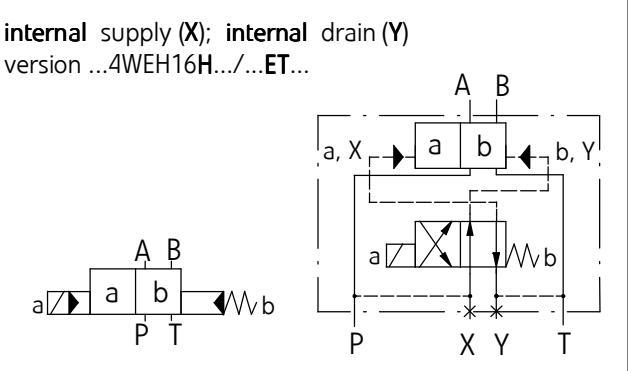
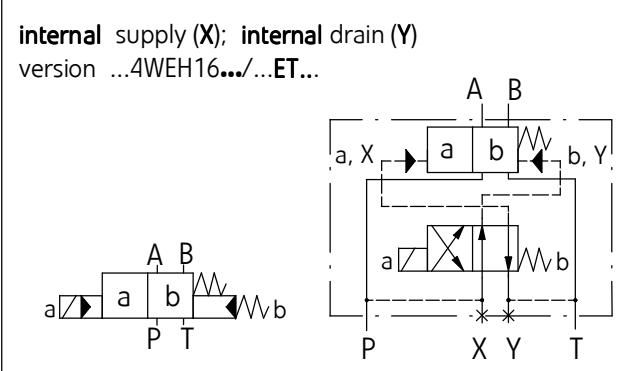

# DIAGRAMS

Simplified and detailed hydraulic schemes for 2-position directional valves with various pilot supply (X) and pilot drain (Y)

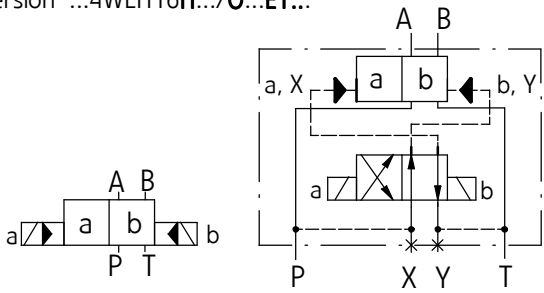
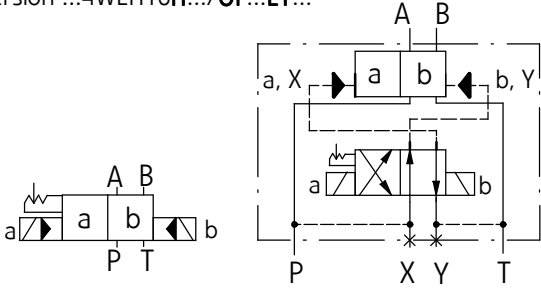
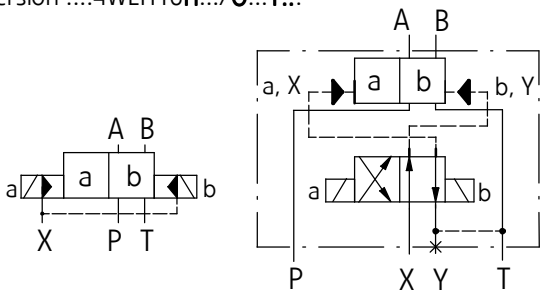
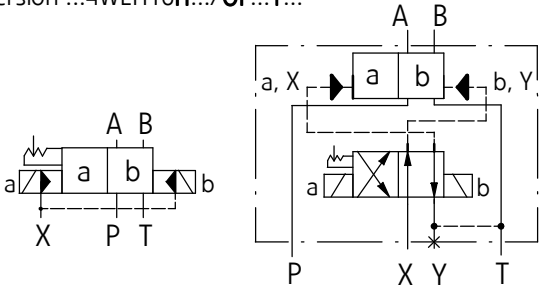
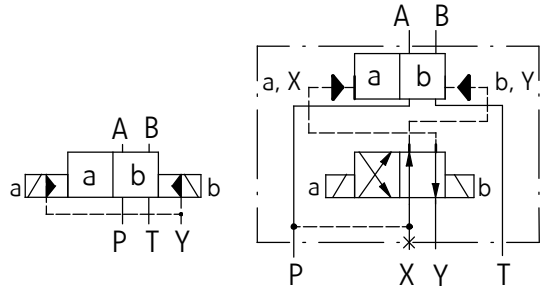
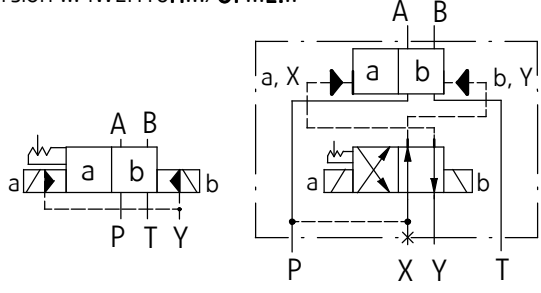
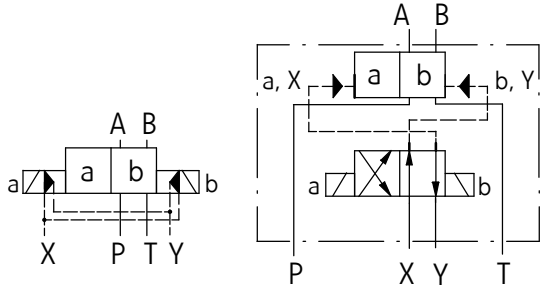
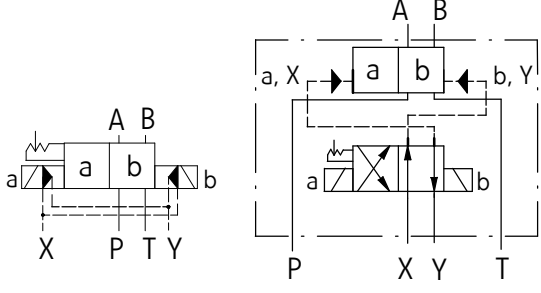
<p>2-position directional valves with hydraulically positioned spool in main valve, pilot valve without return spring version ...4WEH16H.../O...</p>	<p>2-position directional valves with hydraulically positioned spool in main valve, pilot valve without return spring, with detent version ...4WEH16H.../OF...</p>
<p><b>internal supply (X); internal drain (Y)</b> version ...4WEH16H.../O...ET...</p> 	<p><b>internal supply (X); internal drain (Y)</b> version ...4WEH16H.../OF...ET...</p> 
<p><b>external supply (X); internal drain (Y)</b> version ...4WEH16H.../O...T...</p> 	<p><b>external supply (X); internal drain (Y)</b> version ...4WEH16H.../OF...T...</p> 
<p><b>internal supply (X); external drain (Y)</b> version ...4WEH16H.../O...E...</p> 	<p><b>internal supply (X); external drain (Y)</b> version ...4WEH16H.../OF...E...</p> 
<p><b>external supply (X); external drain (Y)</b> version...4WEH16H.../O...</p> 	<p><b>external supply (X); external drain (Y)</b> version ...4WEH16H.../OF...</p> 

# DIAGRAMS

## Diagrams of spools

### 3-position

versions ...4WEH16...

working and indirect positions

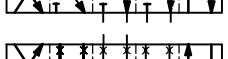
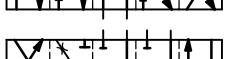
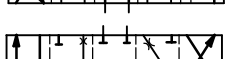
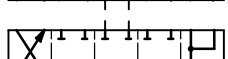
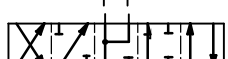
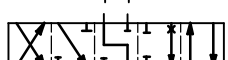
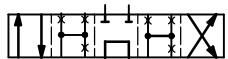
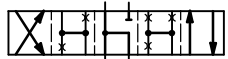
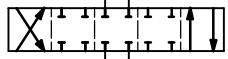
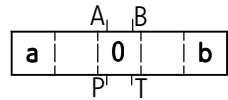

working positions

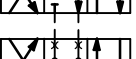
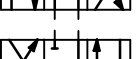
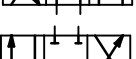
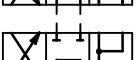
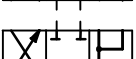
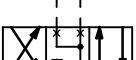
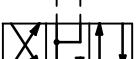
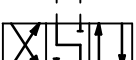
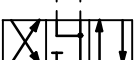
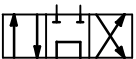
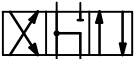
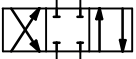
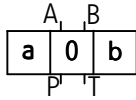

### 2-position (a, 0)

versions ...4WEH16...A...

working and indirect positions

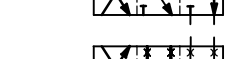
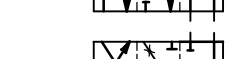
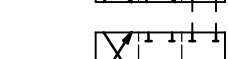
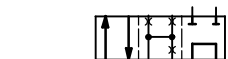
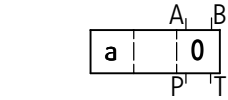

working positions

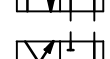
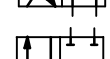
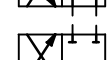
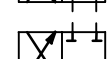
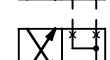
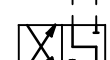
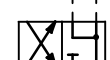
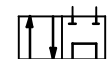
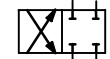
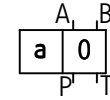

### 2-position (0, b)

versions ...4WEH16...B...

working and indirect positions

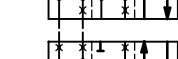
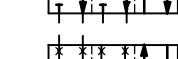
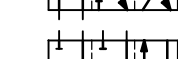
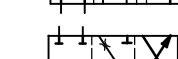
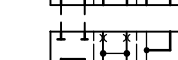
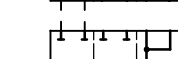
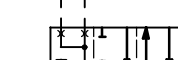
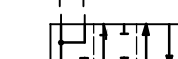
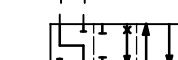
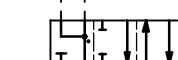
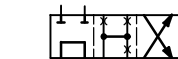
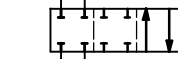
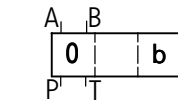

working positions

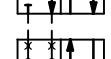
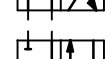
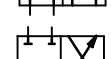
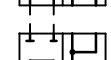
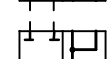
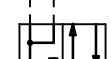
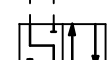
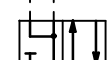
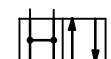
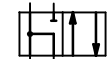
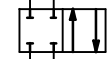
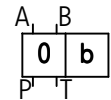

### 2-position (a, b)

versions ...4WEH16...

working and indirect positions

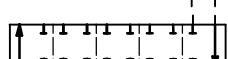
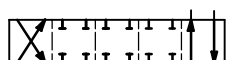
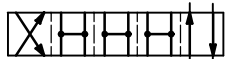
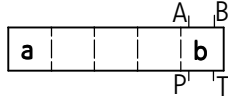

working positions

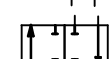
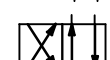
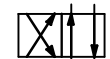
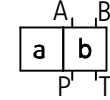



# OVERALL AND CONNECTION DIMENSIONS

3-position standard versions ...4WEH16...S...D1...

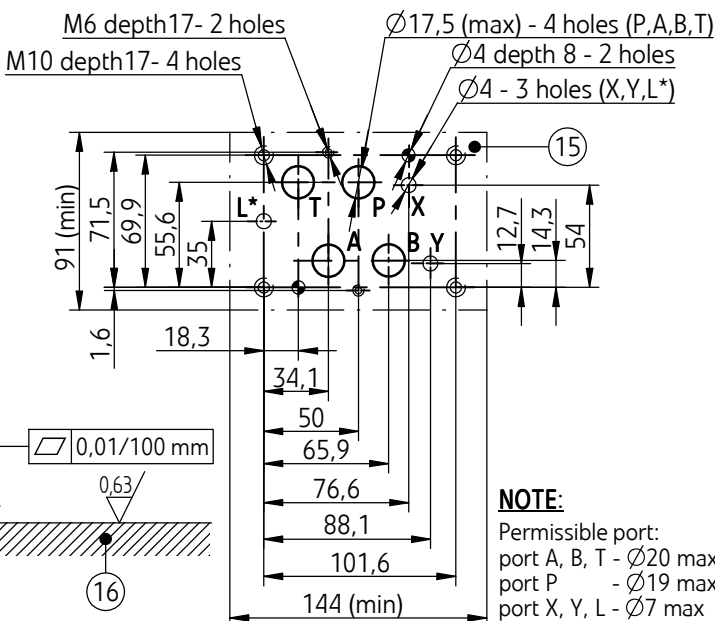
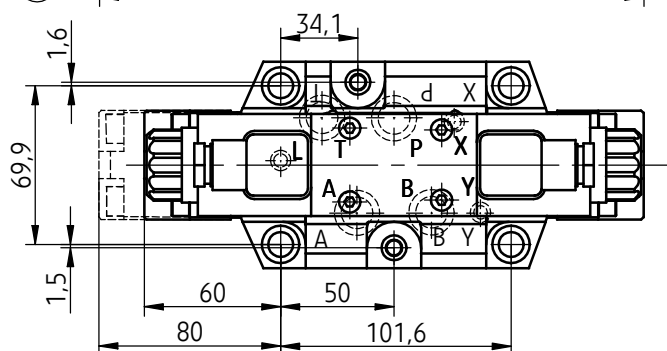
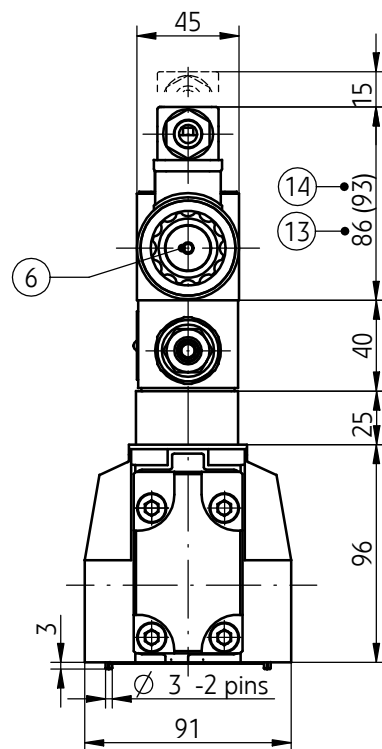
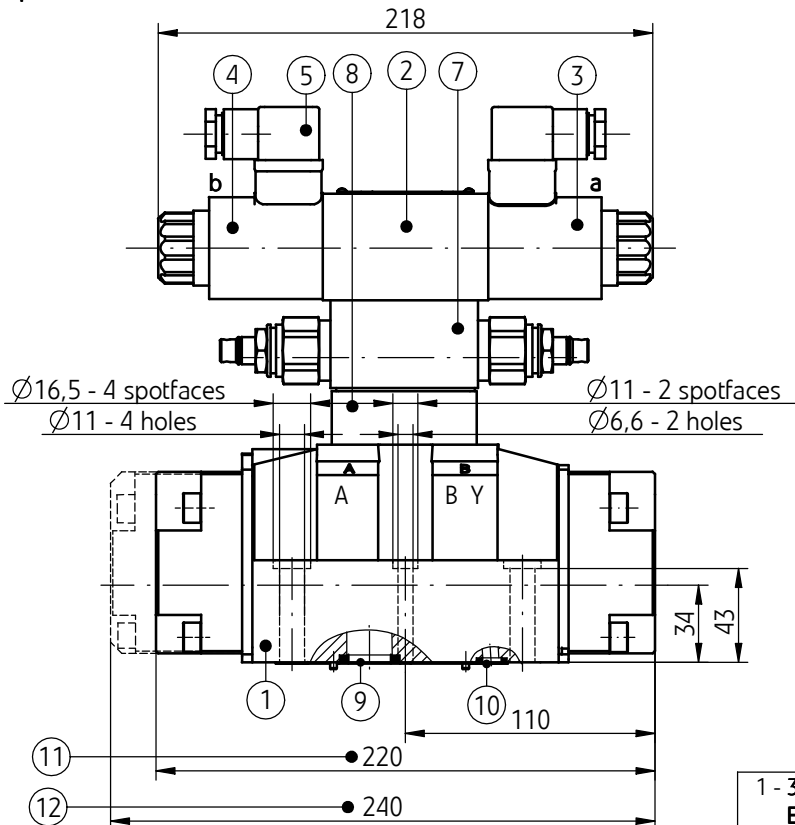

**NOTE:**  
Permissible port:  
port A, B, T - Ø20 max  
port P - Ø19 max  
port X, Y, L - Ø7 max

- 1 - **3-position** main directional valve (spool diagrams: **E, F, G, H, J, L, M, P, Q, R, U, V, W** - on page 8)
- 2 - **3-position** directional valve (pilot valve) type **WE6...** according to data sheet **WK 420 970** (spool types according to technical data on page 4)
- 3 - Solenoid on side **a**
- 4 - Solenoid on side **b**
- 5 - Plug-in-connector type **ISO 4400** (DIN 43650 - A) on side **a** and **b** (other options see page 12)
- 6 - Manual override
- 7 - Pilot choke adjustment (optional accessories) type **ZZFS6...** according to data sheet **WK 421 060**
- 8 - Pressure ratio valve (optional accessories)
- 9 - **Square cross-section** sealing ring **22,5 x 2,1** - 4 pcs/set (P, T, A, B)
- 10 - **Square cross-section** sealing ring **10 x 2** - 3 pcs/set (X, Y, L)
- 11 - Dimension for directional valve with the spool position **0** (neutral) **spring centered** (version ...4WEH16...)
- 12 - Dimension for directional valve with the spool position **0** (neutral) **hydraulically centered** (version ...4WEH16H...)
- 13 - Dimension for electrical connection for **DC**
- 14 - Dimension for electrical connection for **AC** (plug-in-connector with rectifier)
- 15 - Porting pattern - configuration of surface holes in subplate in accordance with the standard **ISO 4401** - identified by **ISO 4401-07-06-0-94** (nominal size CETOP 07) fixing screws in accordance with **PN - EN ISO 4762 M10 x 60 - 10.9** - 4 pcs/set; tightening torque **Md = 62 Nm**  
**M6 x 60 - 10.9** - 2 pcs/set tightening torque **Md = 12,5 Nm**
- NOTE:**  
(\*) - only for 3-position versions with **0** (neutral) position of the spool hydraulically centered
- 16 - Subplate surface required

# OVERALL AND CONNECTION DIMENSIONS

2-position standard versions ...4WEH16...S...D...

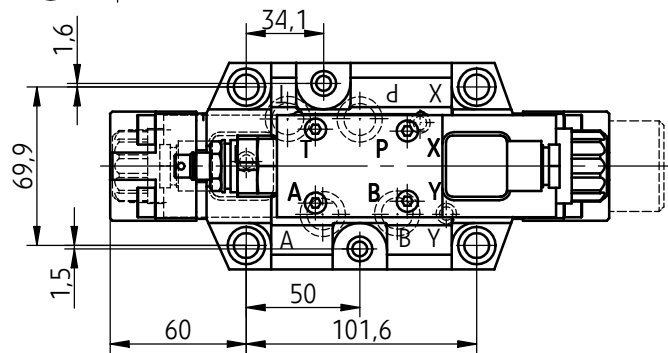
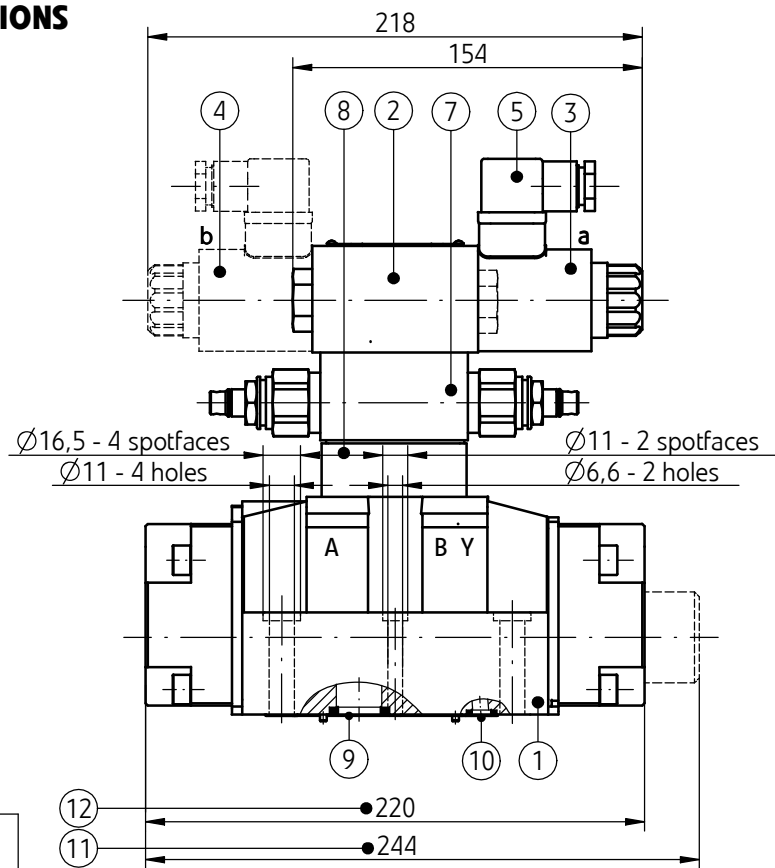
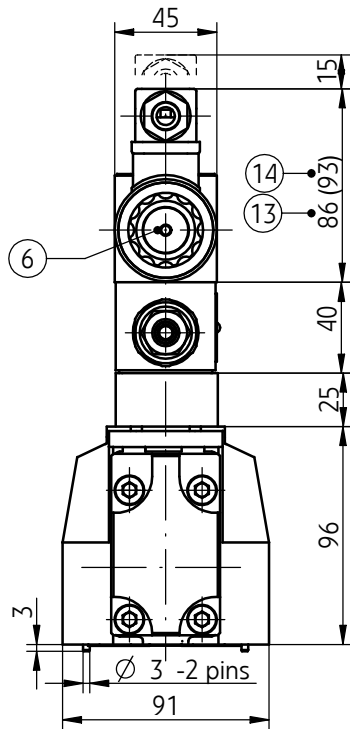

M6 depth 17- 2 holes  
 M10 depth 17- 4 holes  
 Ø17,5 (max) - 4 holes (P,A,B,T)  
 Ø4 depth 8 - 2 holes  
 Ø4 - 3 holes (X,Y,L\*)

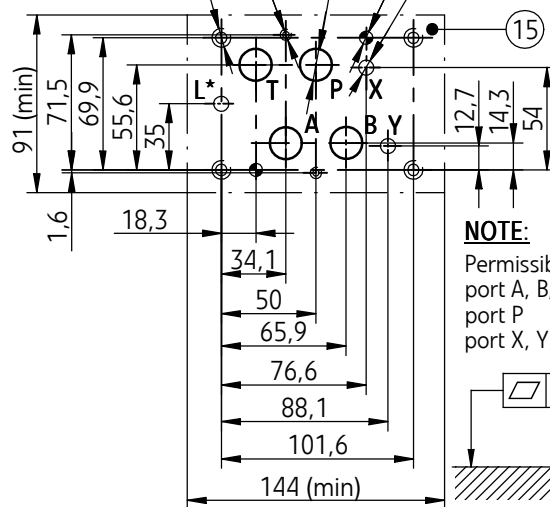

**NOTE:**  
 Permissible port:  
 port A, B, T - Ø20 max  
 port P - Ø19 max  
 port X, Y, L - Ø7 max

0,01/100 mm

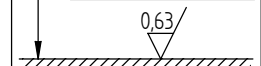

- 1 - 2-position main directional valve (spool diagrams: C, D, K, Z - on page 8)
- 2 - **2-position** directional valve (pilot valve) type WE6... according to data sheet **WK 420 970** (spool types according to technical data on page 4)
- 3 - Solenoid on side **a**
- 4 - Solenoid on side **b** - only for versions: ...4WEH16...7X/O...4WEH16...7X/OF...
- 5 - Plug-in-connector type **ISO 4400** (DIN 43650 - A) on side **a** and **b** (other options see page 12)
- 6 - Manual override
- 7 - Pilot choke adjustment (optional accessories) type **Z2FS6...** according to data sheet **WK 421 060**
- 8 - Pressure ratio valve (optional accessories)
- 9 - **Square cross-section** sealing ring **22,5 x 2,1** - 4 pcs/set (P, T, A, B)
- 10 - **Square cross-section** sealing ring **10 x 2** - 3 pcs/set (X, Y, L)
- 11 - Dimension for directional valve with **spring positioned** spool (version ...4WEH16...)
- 12 - Dimension for directional valve with **hydraulically positioned** spool (version ...4WEH16H...)
- 13 - Dimension for electrical connection for **DC**
- 14 - Dimension for electrical connection for **AC** (plug-in-connector with rectifier)
- 15 - Porting pattern - configuration of surface holes in subplate in accordance with the standard **ISO 4401** - identified by **ISO 4401-07-06-0-94** (nominal size CETOP 07) fixing screws in accordance with **PN - EN ISO 4762 M10 x 60 - 10.9** - 4 pcs/set tightening torque **Md = 62 Nm**  
**M6 x 60 - 10.9** - 2 pcs/set tightening torque **Md = 12,5 Nm**  
**NOTE:**  
 (\*) - only for 3-position versions with **0** (neutral) position of the spool hydraulically centered
- 16 - Subplate surface required

# OVERALL AND CONNECTION DIMENSIONS

2-position standard versions: ...4WEH16...A...S...D...  
 ...4WEH16...B...S...D...

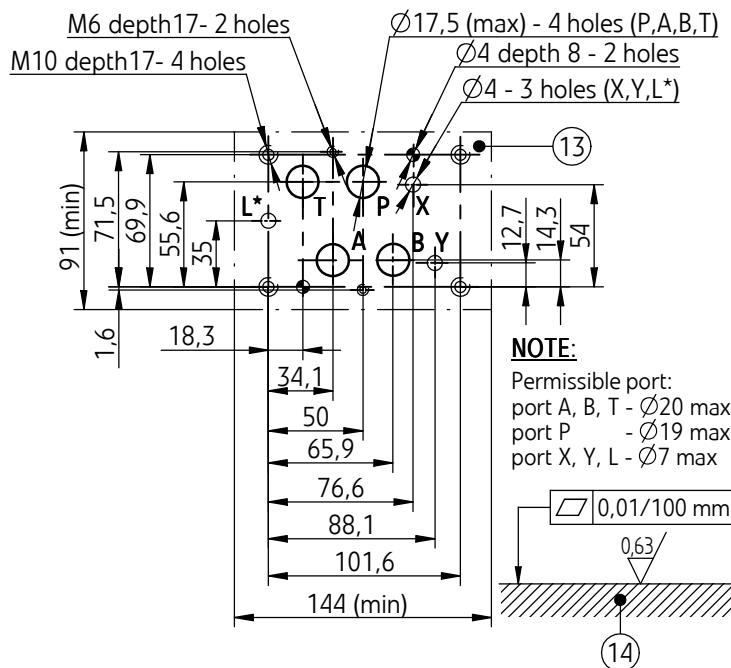
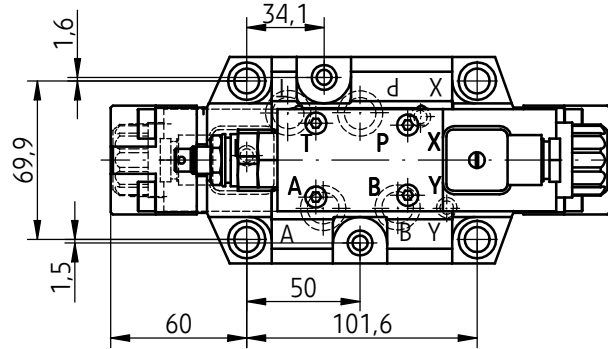
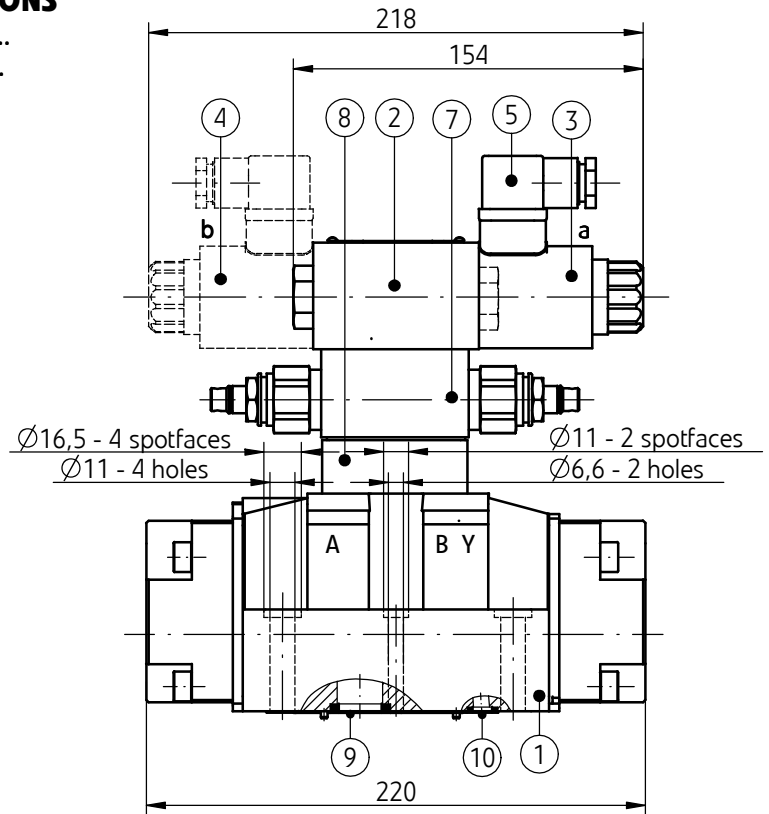
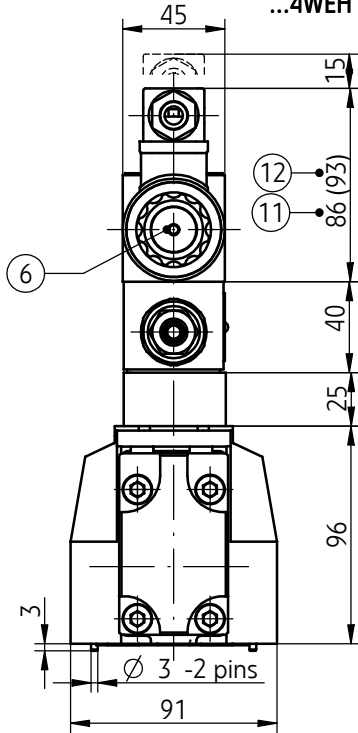

**NOTE:**

Permissible port:  
 port A, B, T - Ø20 max  
 port P - Ø19 max  
 port X, Y, L - Ø7 max

- 1 - 3-position main directional valve - versions:
    - ...4WEH16...A... (spool diagrams: EA, FA, GA, HA, JA, LA, MA, PA, QA, RA, UA, VA, WA - on page 8)
    - ...4WEH16...B... (spool diagrams: EB, FB, GB, HB, JB, LB, MB, PB, QB, RB, UB, VB, WB - on page 8)
  - 2 - 2-position directional valve (pilot valve) type WE6... according to data sheet WK 420 970 (spool types according to technical data on page 4)
  - 3 - Solenoid on side a - for version ...4WEH16...A...
  - 4 - Solenoid on side b - for version ...4WEH16...B...
  - 5 - Plug-in-connector type ISO 4400 (DIN 43650 - A) on side a and b (other options see page 12)
  - 6 - Manual override
  - 7 - Pilot choke adjustment (optional accessories) type Z2FS6... according to data sheet WK 421 060
  - 8 - Pressure ratio valve (optional accessories)
  - 9 - Square cross-section sealing ring 22,5 x 2,1 - 4 pcs/set (P, T, A, B)
  - 10 - Square cross-section sealing ring 10 x 2 - 3 pcs/set (X, Y, L)
  - 11 - Dimension for electrical connection for DC
  - 12 - Dimension for electrical connection for AC (plug-in-connector with rectifier)
  - 13 - Porting pattern - configuration of surface holes in subplate in accordance with the standard ISO 4401 - identified by ISO 4401-07-06-0-94 (nominal size CETOP 07) fixing screws in accordance with PN - EN ISO 4762
    - M10 x 60 - 10.9 - 4 pcs/set tightening torque Md = 62 Nm
    - M6 x 60 - 10.9 - 2 pcs/set tightening torque Md = 12,5 Nm
- NOTE:**  
 (\*) - only for 3-position versions with Ø (neutral) position of the spool hydraulically centered
- 14- Subplate surface required

## OVERALL AND CONNECTION DIMENSIONS

options of electrical connection of pilot valve solenoids  
(further information according to Data Sheet **WK 420 970**)

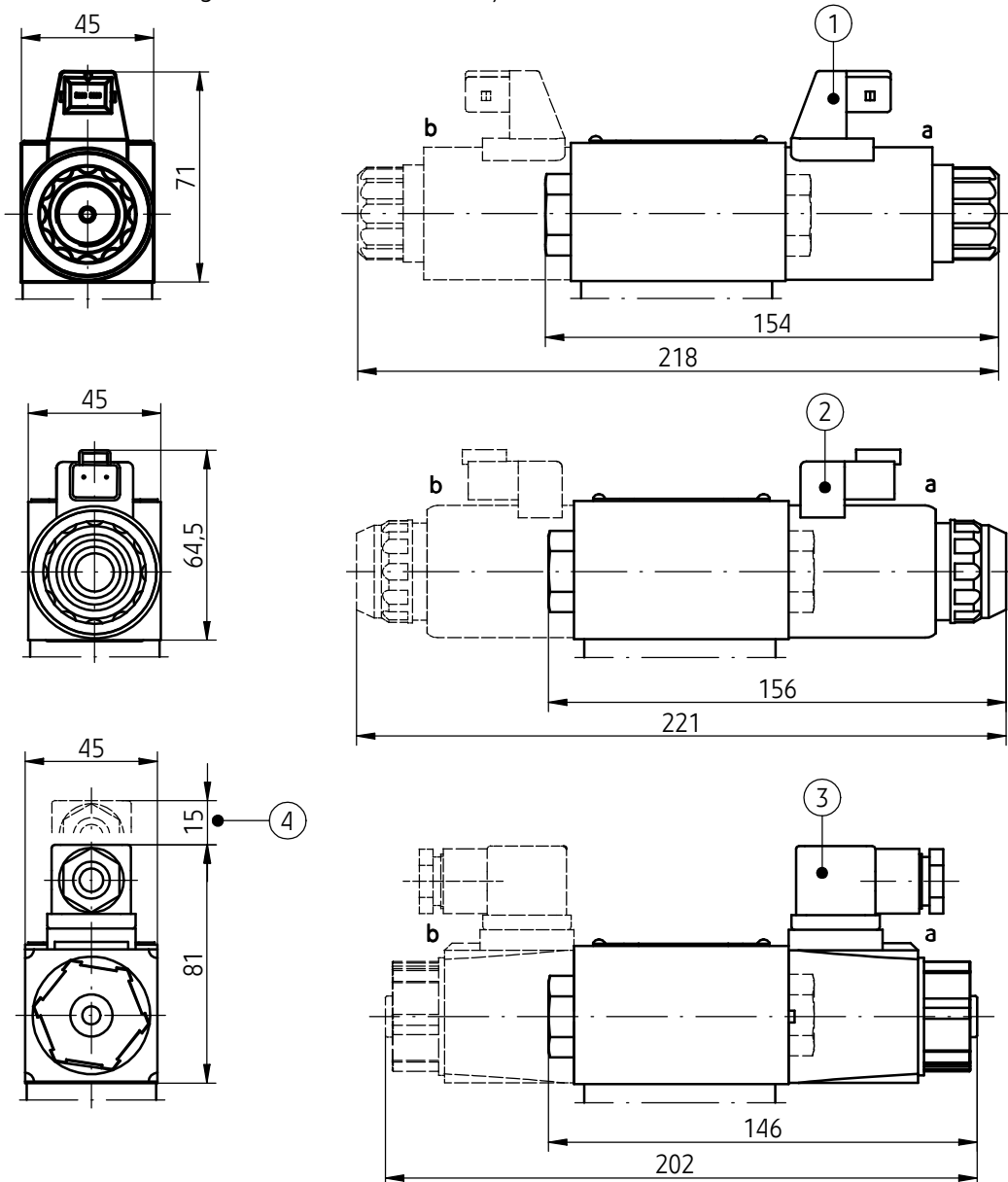

- 1 - Versions WEH16...G12...J...; ...G24...J... - DC solenoids; connector type **AMP Junior Timer male 2-pole** (plug-in-connectors not shown in the drawing must be ordered separately - see Data Sheet **WK 499 963**)
  - 2 - Version WEH16...G24...D... - DC solenoids; connector type **Deutsch DT04 - 2P** (plug-in-connectors type **Deutsch DT06 - 2S** not shown in the drawing must be ordered separately - see Data Sheet **WK 499 963**)
  - 3 - Versions WEH16...W230 - 50...Z4... - AC solenoids (with direct supply); plug-in-connectors type **ISO 4400**
- NOTE:**  
simultaneous joining of two solenoids of the same pilot valve should not be permitted (partial overriding of the valve can overheat and damage the winding coils)
- 4 - Distance for dismantling of plug from solenoid connector

## ACCESSORIES FOR STANDARD VERSION OF THE DIRECTIONAL VALVE

### Pilot choke adjustment

versions: ...4WEH16.../...S...  
...4WEH16.../...S2...

Directional spool valve type ...4WEH16... may be optionally provided with pilot choke adjustment (throttle check valve type Z2FS6...), which allows to adjust switching time directional spool valve.

The change of adjustment method of switching time (flow throttling):

- on inlet (version ...4WEH16.../S...)
- on outlet (version ...4WEH16.../S2...)

is made while mounting by rotating the pilot choke adjustment (3) o 180 degrees around its longitudinal axis. Rotation of the adjusting screw (5) clockwise increases and counterclockwise decreases the switching of the valve.

Screws M5 x 90 - 10.9 acc. to PN - EN ISO 4762 - 4 pcs fixing the adjustment (3) and the initial valve (2) must be tightened with torque **Md = 9 Nm**.

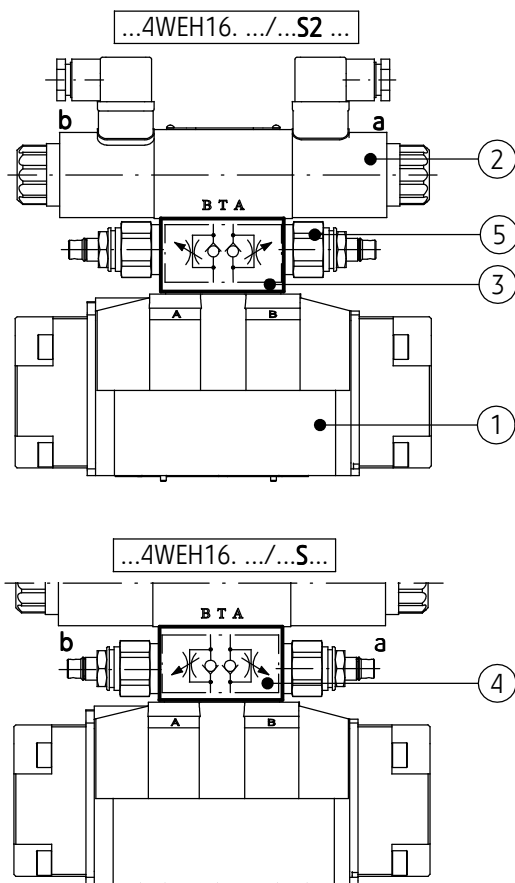

### Pressure ratio valve

versions: ...4WEH16.../...ET...D1...  
...4WEH16.../...E...D1...

The directional control valve type ...4WEH16... with internal pilot oil supply - versions: ...E...;...ET... **at the pilot oil supply pressure exceeding 25 MPa must be equipped with a pressure ratio valve (6).**

It causes the pilot pressure to be reduced at the ratio 1:0,66 = 1,515. The minimum control pressure when applying the pressure ratio valve must be increased by the ratio 1:0,66 = 1,515.

The screws **M5 x 115 - 10.9** acc. to **PN - EN ISO 4762** 4 pcs fixing the pressure ratio valve (6) and the pilot choke adjustment (3) must be tightened with torque **Md = 9Nm**.

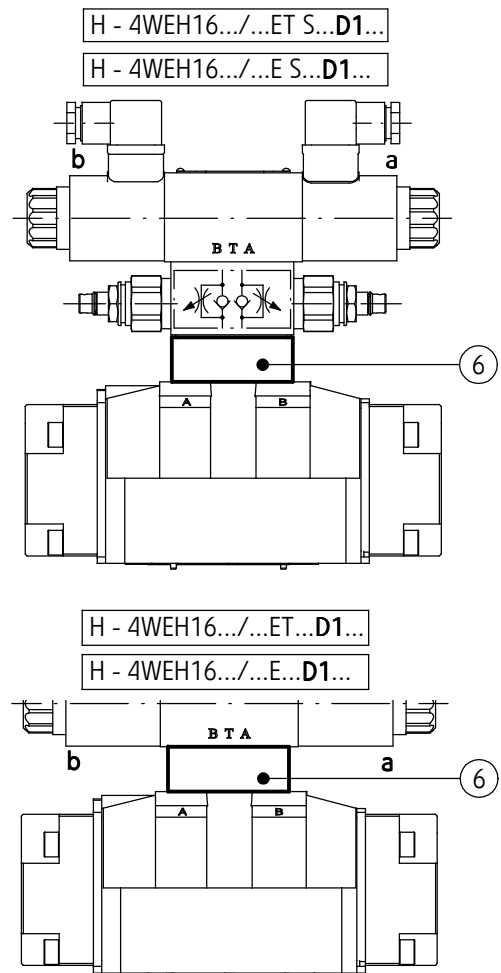

- 1 - Main valve
- 2 - Pilot valve
- 3 - Pilot choke adjustment with adjustment of switching time on outlet
- 4 - Assembly method of pilot choke adjustment with adjustment of switching time at the inlet
- 5 - Adjusting screw
- 6 - Pressure ratio valve

## ACCESSORIES FOR STANDARD VERSION OF THE DIRECTIONAL VALVE

### Pre-load valve

versions: ...4WEH16.../...P4,5...  
...4WEH16.../...P7...

Directional valve type...4WEH16... with internal pilot oil supply (X) - versions: ...E...; ...ET... with spools C, Z, F, G, H, S, T, V (diagrams according to page 8) with pressureless circulation of hydraulic fluid (supply and drain connected at working or indirect positions) **must be equipped with the pre-load valve (2) fixed in port P** of the main valve (1).

Cracking pressure for pre-load valves:

version P 4.5 - 0,45 MPa

version P 7 - 0,7 MPa

For directional valves with fixed pressure ratio valve - versions H4 - 4WEH16.../...D1... the pre-load valve P7 must be applied.

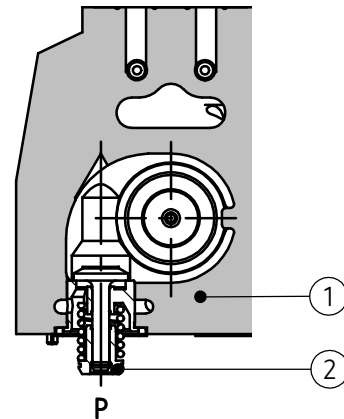

1 - Main valve body  
2 - Pre-load valve

### Performance curves for pre-load valves

(measured at viscosity  $\nu = 41 \text{ mm}^2/\text{s}$  and temperature  $t = 50^\circ\text{C}$ )

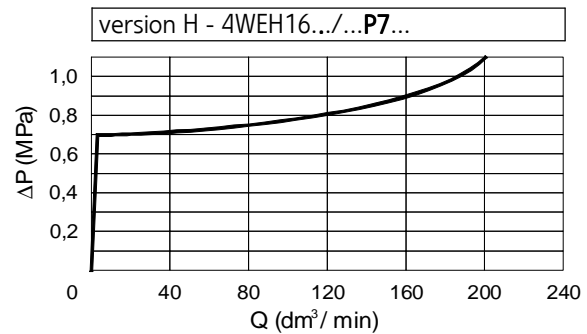
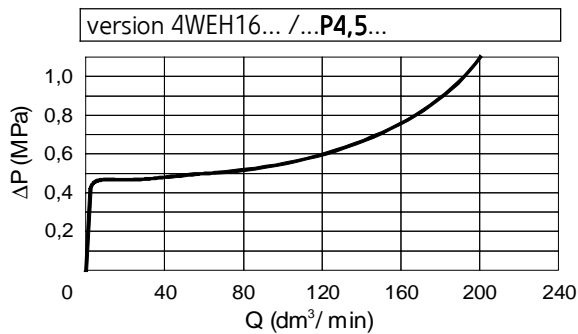

### Throttle insert

version ...4WEH16.../...B...

Directional valves type ...4WEH16... may be equipped with throttle insert (3) in port P in pilot valve (2) which allows to delay switching time of the main valve.

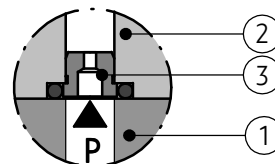

1 - Main valve  
2 - Pilot valve  
3 - Throttle insert

## ACCESSORIES FOR STANDARD DIRECTIONAL VALVE

### Pilot oil supply and pilot oil drain

Pilot oil supply (X) - external  
pilot oil drain (Y) - external  
version ...4WEH16.../...

In version...4WEH16.../... the hole screw plugs (3) and (5) and plugs (4) and (6) must be mounted in the position like given on the drawing.

Pilot oil supply (X) - internal  
pilot oil drain (Y) - external  
version ...4WEH16.../...E...

In version ...4WEH16.../...E... the hole screw plug (3) must be dismantled whereas the hole screw plug (5), plugs (4) and (6) must be mounted and port X in a subplate should be plugged.

Pilot oil supply (X) - internal  
pilot oil drain (Y) - internal  
version ...4WEH16.../...ET...

In version ...4WEH16.../...ET... the hole screw plugs (3) and (5) must be dismantled whereas the plugs (4) and (6) must be mounted and ports X and Y in a subplate must be plugged.

Pilot oil supply (X) - external  
pilot oil drain (Y) - internal  
version ...4WEH16.../...T...

In version ...4WEH16.../...T... the hole screw plug (3) must be mounted whereas the hole screw plug (5) must be dismantled. The plugs (4) and (6) must be mounted and the port Y in a subplate must be plugged.

### NOTES:

Versions with internal oil drain:...ET...; ...T... are non-applicable for directional valves with main spool hydraulically centered (versions...4WEH16H...).

The hole screw plug (3) in port X is accessible after screwing out a side cover (2) in the main valve (1).

The hole screw plug (5) in port Y is accessible after dismantling the pilot valve (7).

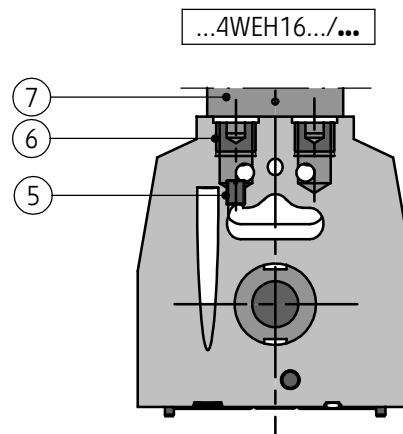
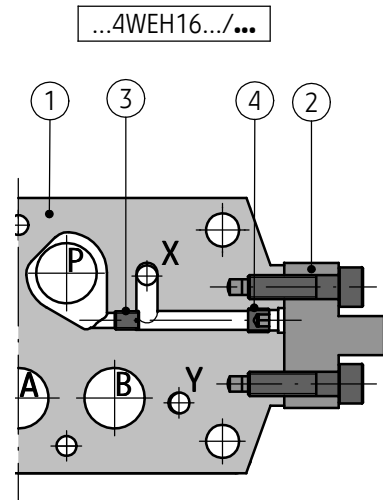

- 1 - Main valve body
- 2 - Side cover
- 3 - Hole screw plug **M6 - 8,8** (S3)
- 4 - Plug
- 5 - Hole screw plug **M6 - 8,8** (S3)
- 6 - Plug
- 7 - Pilot valve body

## OPTIONAL ACCESSORIES FOR DIRECTIONAL VALVE

Stroke limiter of the spool may be mounted:

- stroke limiter on valve ends **A** and **B**  
version ...4WEH16.../...10...
- stroke limiter on valve end **A**  
version ...4WEH16.../...11...
- stroke limiter on valve end **B**  
version ...4WEH16.../...12...

Adjustment of the stroke of the main spool is by rotating the pin (3) and securing with locknut (4). Rotating the pin (3) clockwise reduces the stroke of the main spool (2). While adjusting the stroke the control chamber must be at zero pressure.

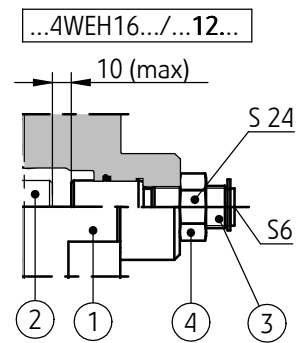

- 1 - Stroke limiter body (on valve end **B**)
- 2 - Spool of the main valve
- 3 - Pin
- 4 - Locknut

### End position monitor

End position monitor may be mounted:

- on valve end **A**  
versions: ...4WEH16.../...18... (contact breaker)  
...4WEH16.../...22... (contact maker)
- on valve end **B**  
versions: ...4WEH16.../...19... (contact breaker)  
...4WEH16.../...23... (contact maker)

Directional valves type ...4WEH16... may be equipped with spool end position monitor, optionally contact maker or contact breaker, mounted depending on the version, in main valve cover on valve end **A** or **B** - overall dimensions on pages 24 - 27.

Detailed information concerning proximity sensors and plug-in connectors given on page 4.

sensor position	signal level					
	end position monitor with contact breakers (versions 4WEH16.../...18...; ...19...)			end position monitor with contact makers (versions 4WEH16.../...22...; ...23...)		
	spool position			spool position		
	valve body side	central	cover side	valve body side	central	cover side
sensor ① valve body side	0	1	1	1	0	0
sensor ② cover side	1	1	0	0	0	1



# OPTIONAL ACCESSORIES FOR DIRECTIONAL VALVE

## End position monitor

...4WEH16.../...19...

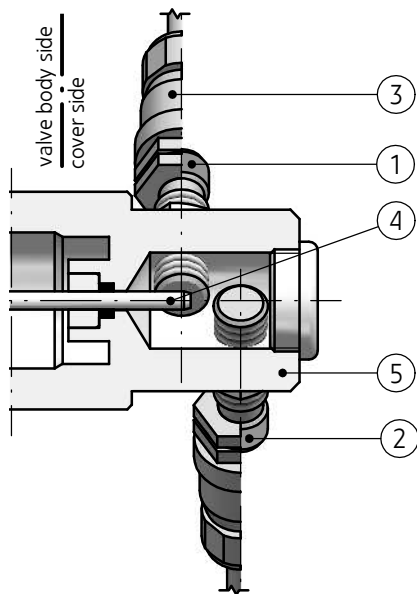

- 1 - Inductive sensor contact maker **PNP NO** according to page 4
- 2 - Inductive sensor contact breaker **PNP NC** according to page 4
- 3 - Plug-in cable connector (straight, female plug-in connectors - according to page 4, 2 pcs delivered with the valve
- 4 - Mandrel of the main spool
- 5 - Sensors cover

### diagram of electrical connection of sensors set contact breaker

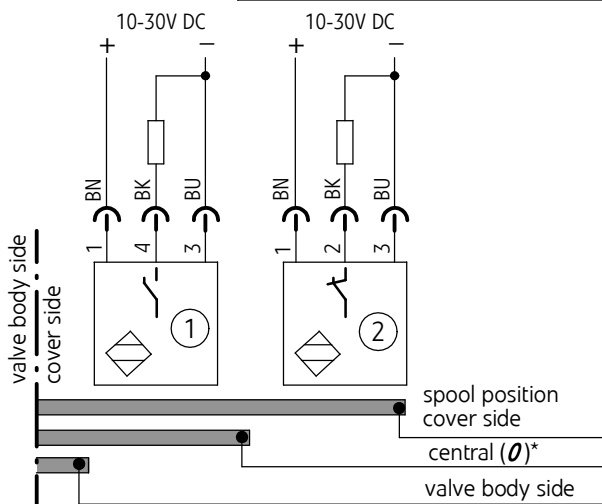
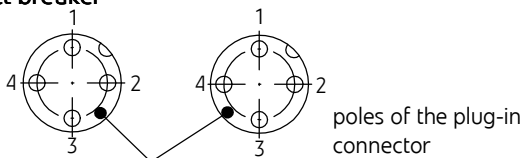

#### NOTE:

(\*) - Only for 3-position directional valves

...4WEH16.../...23...

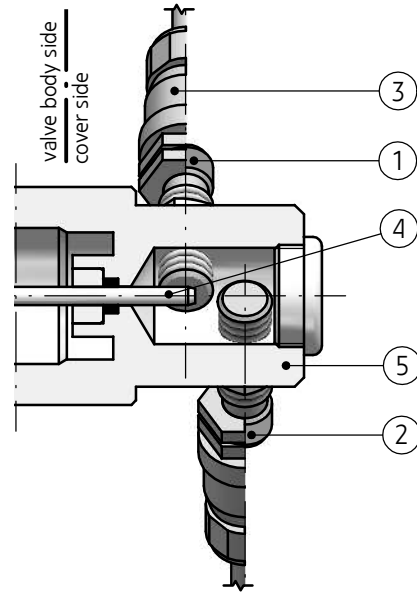

- 1 - Inductive sensor contact breaker **PNP NC** according to page 4
- 2 - Inductive sensor contact maker **PNP NO** according to page 4
- 3 - Plug-in cable connector (straight, female plug-in connectors - according to page 4, 2 pcs delivered with the valve
- 4 - Mandrel of the main spool
- 5 - Sensors cover

### diagram of electrical connection of sensors set contact maker

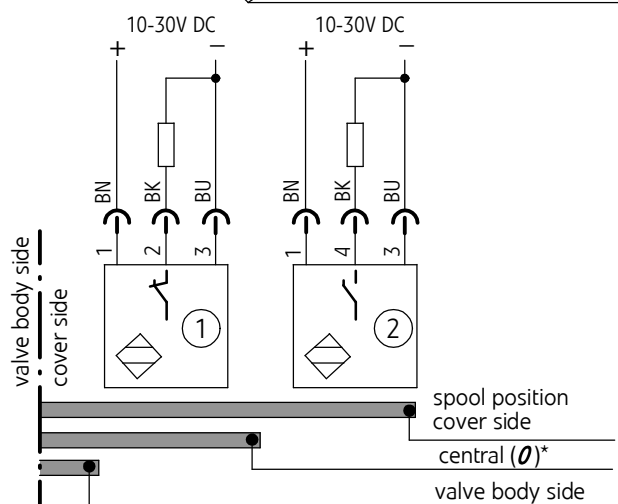
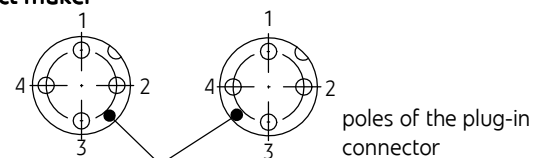

#### NOTE:

(\*) - Only for 3-position directional valves

# OPTIONAL ACCESSORIES FOR THE DIRECTIONAL CONTROL VALVE

## Spool position sensor type M

Additional technical data

<b>Sensor type M</b>	
Type of spool position sensor	sensor with 2 alternative PNP type outputs
Supply voltage range of the sensor	24 VDC $\begin{matrix} +20\% \\ -10\% \end{matrix}$
Max sensor load current	400 mA
Sensor connection type	external thread M12 x1; 4 poles (pins)
Degree of protection	IP 65
<b>WARNING:</b> M type inductive sensors must not be connected serially.	

Diagram of electrical connection of inductive sensor

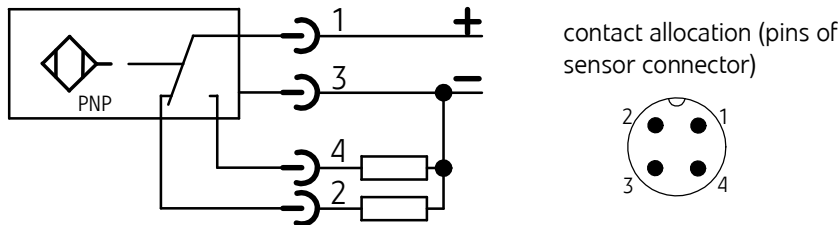

Diagrams for directional control valves and status of sensors

status of sensor type M depending on position of the spool 0 - off, neutral, potential-free state at the output contact 1 - on, voltage state at the output contact		diagram for directional control valve
<p><b>3-position, spring centered versions ...MAB...</b> a and b position monitoring (sensor at the side a and b)</p>	<p><b>3-position, spring centered versions ...M0...</b> 0 position monitoring (sensor at the side a and b)</p>	
<p><b>3-position, spring centered version ...MB...</b> b position monitoring (sensor at the a side).</p>	<p><b>3-position, spring centered versions...MA...</b> a position monitoring (sensor at the b side).</p>	

Diagrams for directional control valves and status of sensors

status of sensor type M depending on position of the spool 0 - off, neutral, potential-free state at the output contact 1 - on, voltage state at the output contact		diagram for directional control valve
<p><b>2-position (a, 0), spring centered</b> versions ...MA... a position monitoring (sensor at the b side)</p>	<p><b>2-position (a, 0), spring centered</b> versions ...M0... 0 position monitoring (sensor at the b side)</p>	
<p><b>2-position (0, b), spring centered</b> versions ...MB... b position monitoring (sensor at the a side)</p>	<p><b>2-position (0, b), spring centered</b> versions ...M0... 0 position monitoring (sensor at the a side)</p>	
<p><b>3-position, hydraulically centered</b> versions ...MA... a position monitoring (sensor at the b side)</p>	<p><b>3-position, hydraulically centered</b> versions ...MB... b position monitoring (sensor at the b side)</p>	
<p><b>2-position (a, 0), hydraulically centered</b> versions ...MA... a position monitoring (sensor at the b side)</p>	<p><b>2-position (a, 0), hydraulically centered</b> versions ...M0... 0 position monitoring (sensor at the b side)</p>	
<p><b>2-position (0, b), hydraulically centered</b> versions ...MB... b position monitoring (sensor at the b side)</p>	<p><b>2-position (0, b), hydraulically centered</b> versions ...M0... 0 position monitoring (sensor at the b side)</p>	
<p><b>2-position (a, b), spring positioned</b> versions ...MA... a position monitoring (sensor at the a side)</p>	<p><b>2-position (a, b) spring positioned</b> versions...MB... b position monitoring (sensor at the a side)</p>	

## OVERALL DIMENSIONS OF THE VALVE WITH OPTIONAL ACCESSORIES

Connection plan and required state of the connection surface - see page 9

### versions with a spool position sensor type M

3-positions, spring centered

**a, b** or **0** position monitoring, sensor at the **A** and **B** side

versions ...**MAB**... or ...**M0**...

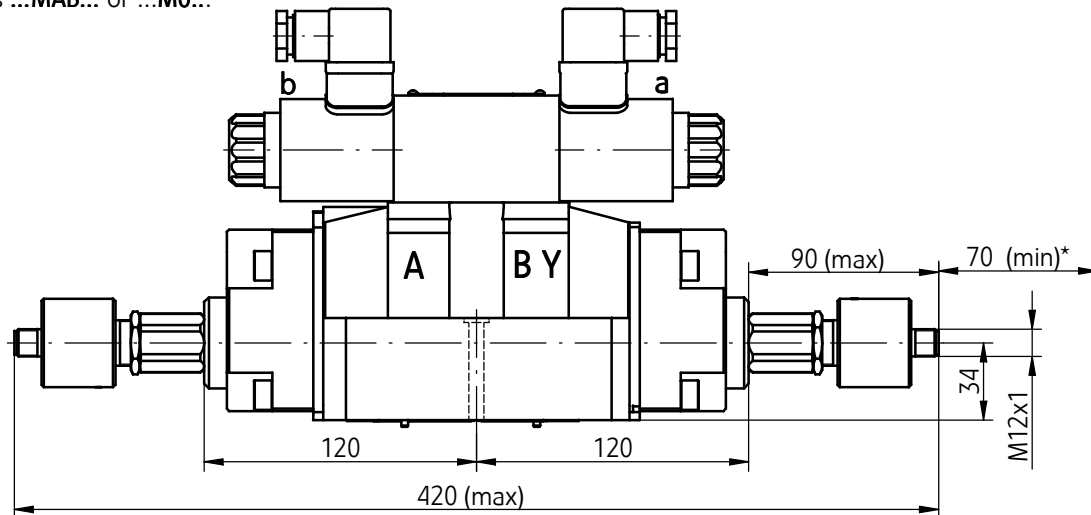

...4WEH16.../...- MAB...

...4WEH16.../...- M0...

#### NOTES:

- the valve with the spool position sensor has been factory calibrated, any further adjustments with in the valve can be made only by the producer
- in case of any defect of the sensor or the valve, the whole valve should be replaced

#### NOTE:

(\* ) - Distance for mounting the plug-in connector and the sensor cable (the plugs not shown on the drawing, supplied on a separate order, Data Sheet **WK 499 963**)

**NOTE:** In compliance with PN-EN 693, the valve should not be equipped with a manual override button.

3-position, spring centered versions

**a** position monitoring, sensor at the **B** side  
version ...**MA**...

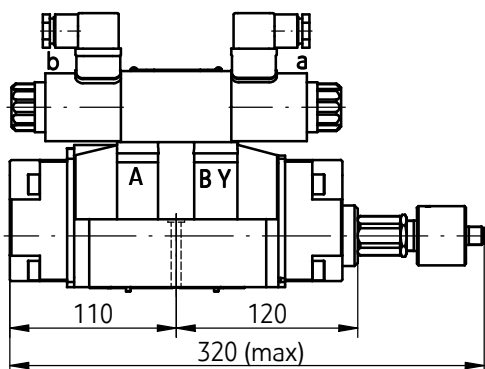

...4WEH16.../...- MA...

3-position, spring centered versions

**b** position monitoring, sensor at the **A** side  
version ...**MB**...

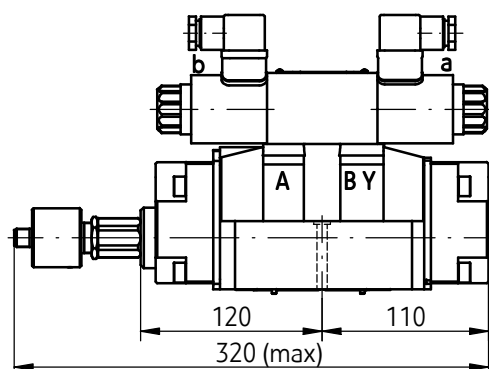

...4WEH16.../...- MB...

# OVERALL DIMENSIONS OF THE VALVE WITH OPTIONAL ACCESSORIES

## versions with a spool position sensor type M

### 3-position, spring centered versions

**a** position monitoring, sensor at the **B** side with a spool stroke limiter at the **A** side version ...**MA11**...

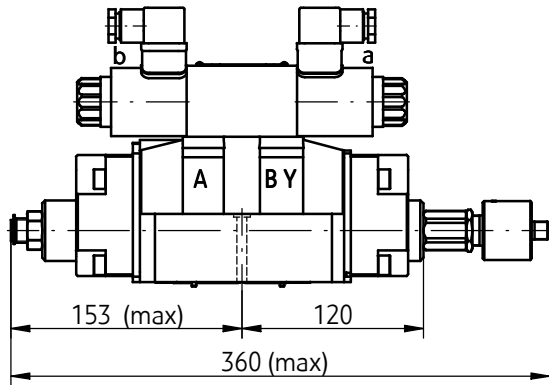

...4WEH16.../...- MA11...

### 3-position, spring centered versions

**b** position monitoring, sensor at the **A** side with a spool stroke limiter at the **B** side version ...**MA12**...

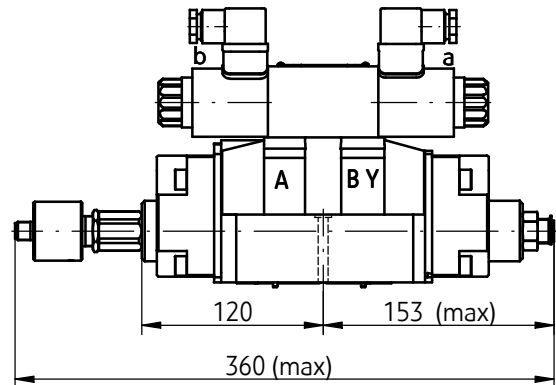

...4WEH16.../...- MB12...

### 2-position (a, 0), spring centered versions

**a** or **0** position monitoring, sensor at the **B** side version ...**MA**... or ...**M0**...

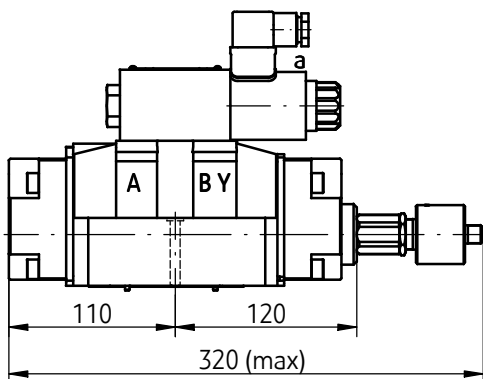

...4WEH16...A.../...- MA...

...4WEH16...A.../...- M0...

### 2-position (0, b), spring centered versions

**b** or **0** position monitoring, sensor at the **A** side version ...**MB**... or ...**M0**...

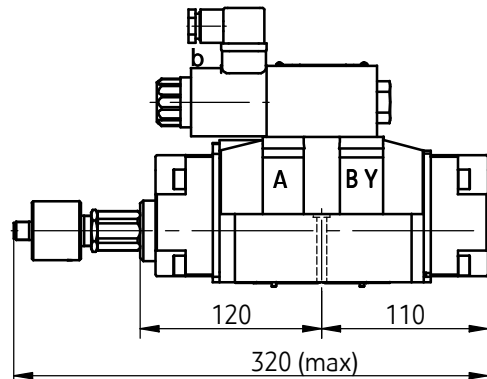

...4WEH16...B.../...- MB...

...4WEH16...B.../...- M0...

## OVERALL DIMENSIONS OF THE VALVE WITH OPTIONAL ACCESSORIES

### versions with a spool position sensor type M

2-position (a, b) spring positioned versions  
a or b position monitoring, sensor at the A side  
version ...MA... or ...MB...

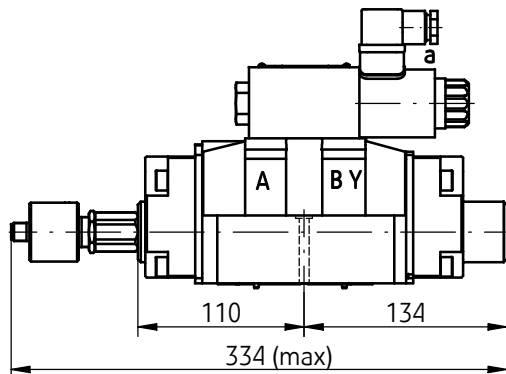

...4WEH16C; ...D...; ...K...; ...Z.../...- MA...  
...4WEH16C; ...D...; ...K...; ...Z.../...- MB...

3-position, hydraulically centered versions  
a or b position monitoring, sensor at the B side  
version ...MA... or ...MB...

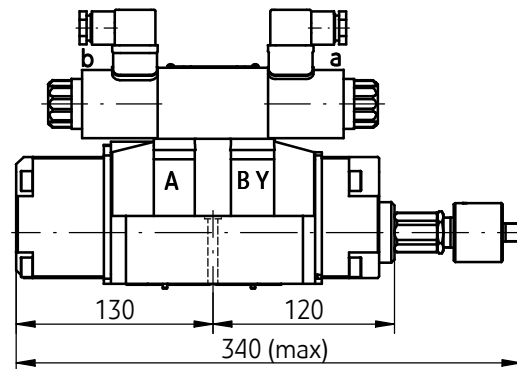

...4WEH16H.../...- MA...  
...4WEH16H.../...- MB...

2-position (a, 0), hydraulically centered versions  
a or 0 position monitoring, sensor at the B side  
version ...MA... or ...M0...

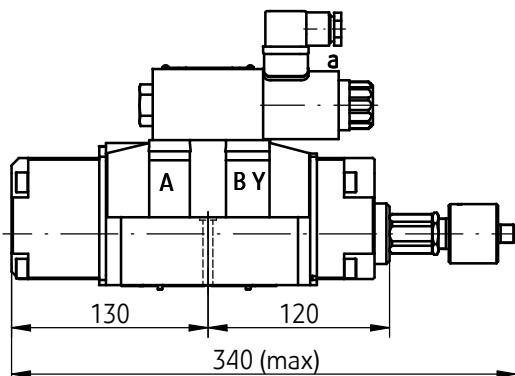

...4WEH16H...A.../...- MA...  
...4WEH16H...A.../...- M0...

2-position (0, b), hydraulically centered versions  
b or 0 position monitoring, sensor at the B side  
version ...MB... or ...M0...

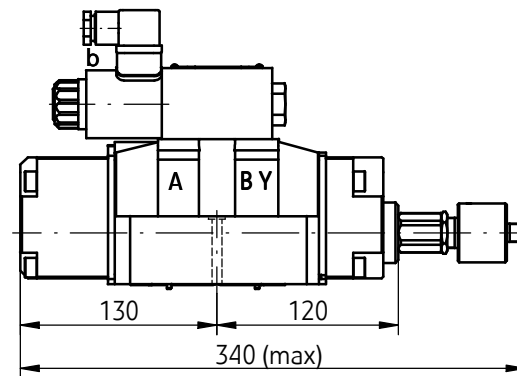

...4WEH16H...B.../...- MB...  
...4WEH16H...B.../...- M0...

## OVERALL DIMENSIONS OF THE VALVE WITH OPTIONAL ACCESSORIES

### versions with stroke limiter

3-position directional valves with the main spool spring centered

stroke limiter may be mounted:

- on side **A** - version ...4WEH16.../...11...
- on side **B** - version ...4WEH16.../...12...
- on sides **A and B** - version ...4WEH16.../...10...

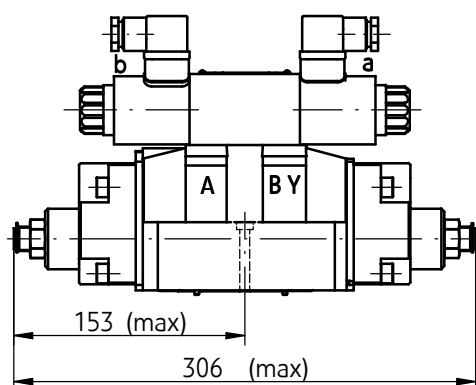

...4WEH16.../...10...

2-position directional valves with the main spool hydraulically positioned

stroke limiter may be mounted:

- on side **A** - version ...4WEH22H.../...11...
- on side **B** - version ...4WEH22H.../...12...
- on sides **A and B** - version ...4WEH22H.../...10...

2 solenoids (on side **a, b**) only for versions 4 WEH16H.../O...; OF...

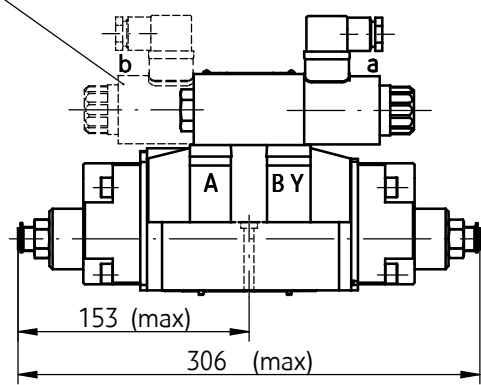

...4WEH16H.../...10...

3-position directional valves with the main spool hydraulically centered

stroke limiter may be mounted:

- on side **B** - version ...4WEH16H.../...12...

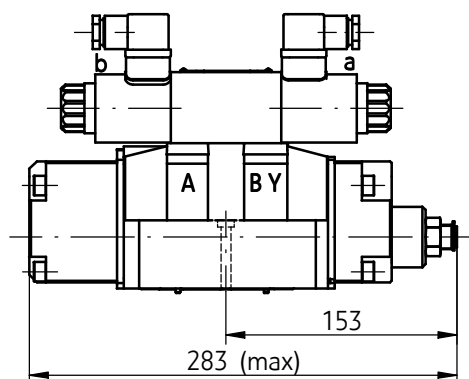

...4WEH16H.../...12...

2-position directional valves with the main spool spring positioned

stroke limiter may be mounted:

- on side **A** - version ...4WEH16.../...11...

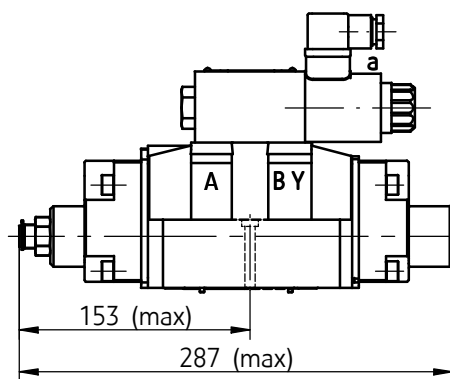

...4WEH16.../...11...

## OVERALL DIMENSIONS OF THE VALVE WITH OPTIONAL ACCESSORIES

### versions with end position monitor

3-position directional valves with spring centered main spool  
end position monitor may be mounted:

- on side **A**  
versions: ...4WEH22.../...18...(contact breaker);...22...(contact maker)
- on side **B**  
versions: ...4WEH22.../...19...(contact breaker);...23...(contact maker)

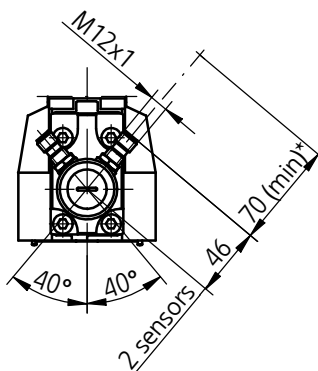
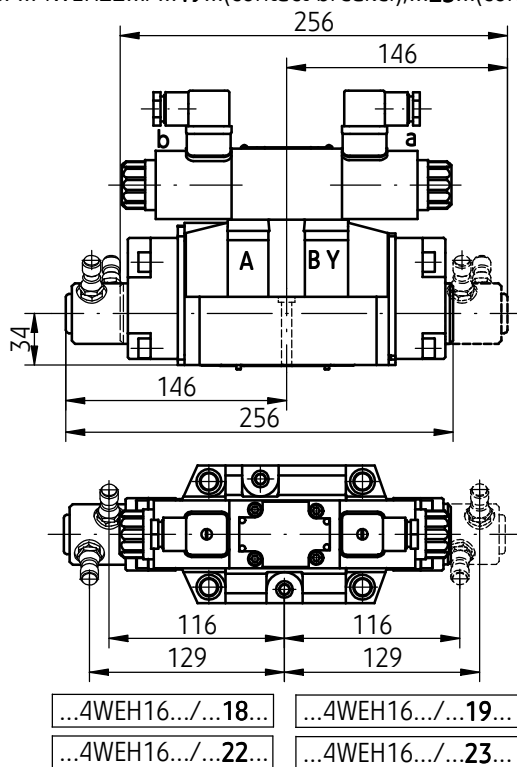

#### NOTE:

(\* ) - Distance for mounting plug-in connector and cable of sensor (plug-in connectors according to page 4 - 2 pcs not shown on drawing, delivered with the valve)

3-position directional valves with hydraulically centered main spool  
end position monitor may be mounted:

- on side **B** - versions: ...4WEH16H.../...19... (contact breaker)  
...4WEH16H.../...23... (contact maker)

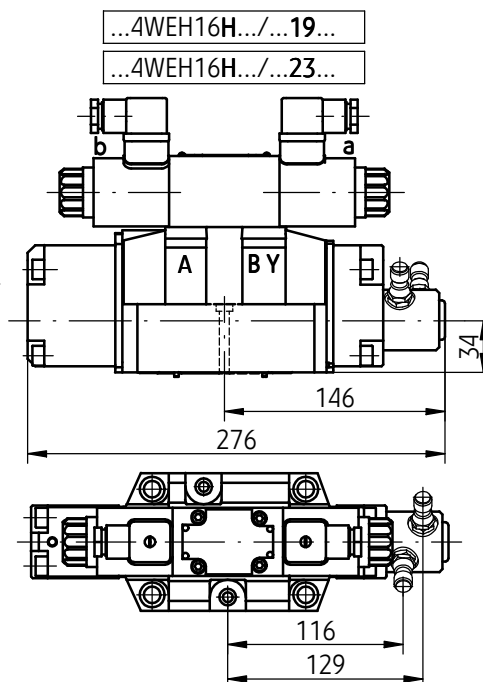
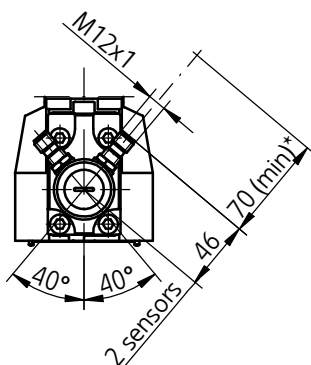

#### NOTE:

(\* ) - Distance for mounting plug-in connector and cable of sensor (plug-in connectors according to page 4 - 2 pcs not shown on drawing, delivered with the valve)



## OVERALL DIMENSIONS OF THE VALVE WITH OPTIONAL ACCESSORIES

### versions with end position monitor

2-position directional valves with spring positioned main spool  
end position monitor may be mounted:

- on side **A**  
versions: ...4WEH16.../...18... (contact breaker)  
...4WEH16.../...22... (contact maker)

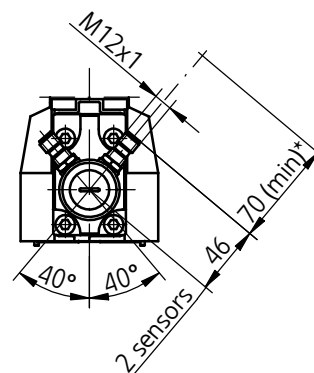
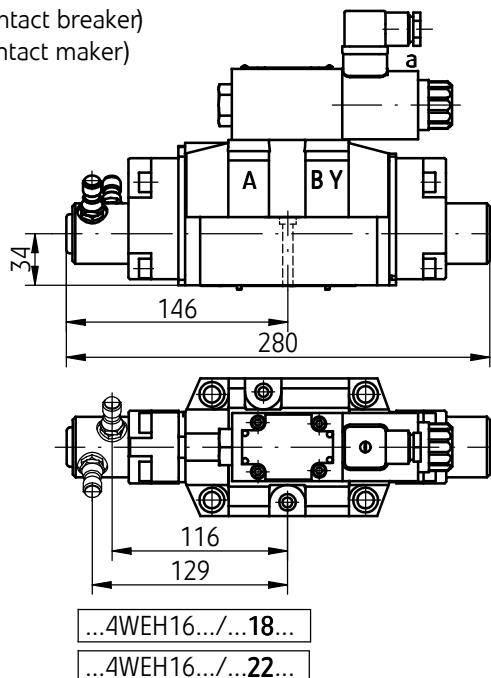

#### NOTE:

(\*) - Distance for mounting plug-in connector and cable of sensor (plug-in connectors according to page 4 - 2 pcs not shown on drawing, delivered with the valve)

2-position directional valves with hydraulically positioned main spool  
end position monitor may be mounted:

- on side **A**  
versions: ...4WEH16H.../...18... (contact breaker) ; ...22... (contact maker)
- on side **B**  
versions: ...4WEH16H.../...19... (contact breaker) ; ...23... (contact maker)

2 solenoids (on side **a, b**) only for versions 4WEH16H.../O...; OF...

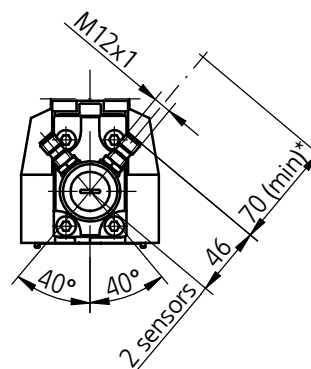
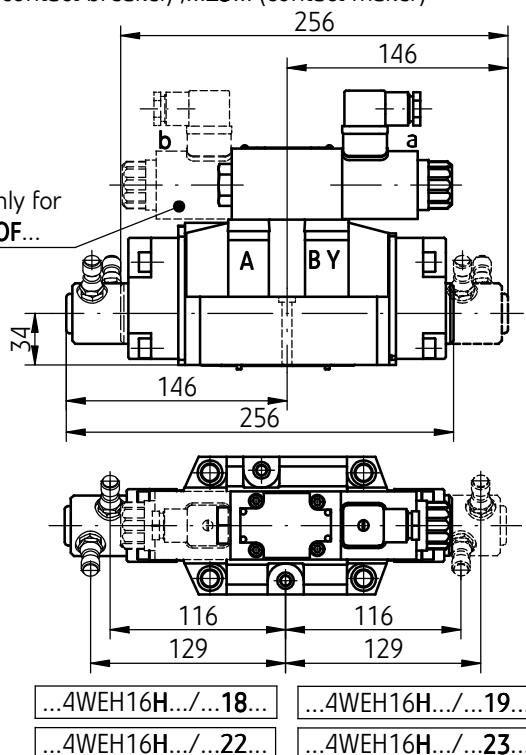

#### NOTE:

(\*) - Distance for mounting plug-in connector and cable of sensor (plug-in connectors according to page 4 - 2 pcs not shown on drawing, delivered with the valve)

## OVERALL DIMENSIONS OF DIRECTIONAL VALVE WITH OPTIONAL ACCESSORIES

### versions with stroke limiter and end position monitor

3-position directional valves with spring centered main spool  
stroke limiter and end position monitor may be mounted:

- stroke limiter on side **A** and end position monitor **contact breaker** on side **B** - version ...4WEH16.../...20...
- stroke limiter on side **A** and end position monitor **contact maker** on side **B** - version ...4WEH16.../...24...
- stroke limiter on side **B** and end position monitor **contact breaker** on side **A** - version ...4WEH16.../...21...
- stroke limiter on side **B** and end position monitor **contact maker** on side **A** - version ...4WEH16.../...25...

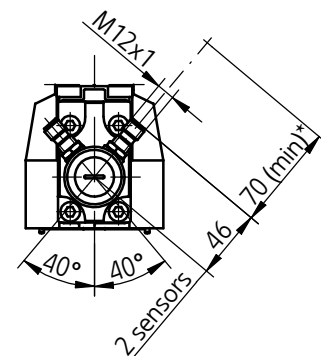
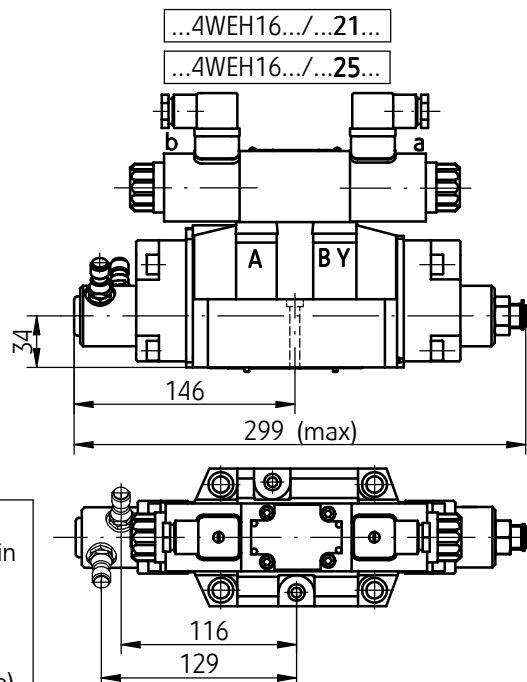
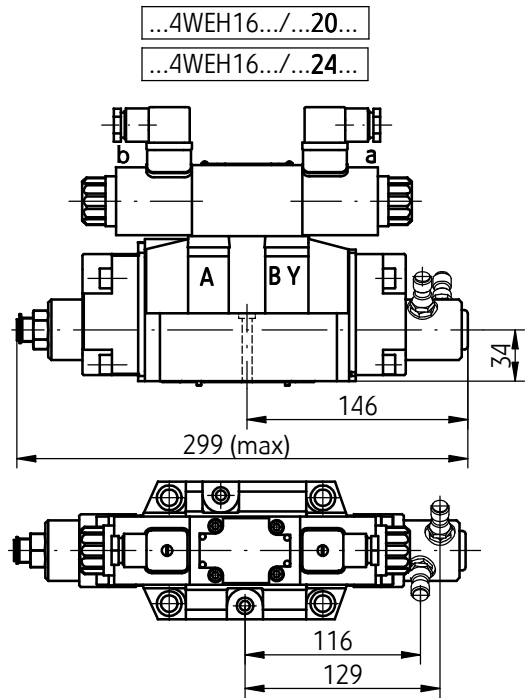
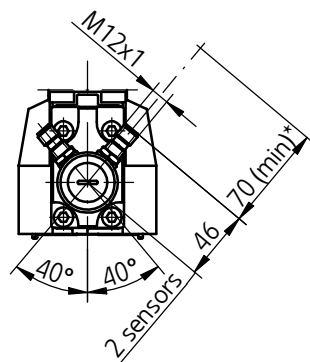

#### NOTE:

(\*) - Distance for mounting plug-in connector and cable of sensor (plug-in connectors according to page 4 - 2 pcs not shown on drawing, delivered with the valve)

# OVERALL DIMENSIONS OF DIRECTIONAL VALVE WITH OPTIONAL ACCESSORIES

## versions with stroke limiter and end position monitor

2-position directional valves with hydraulically positioned main spool stroke limiter and end position monitor may be mounted:

- stroke limiter on side **A** and end position monitor **contact breaker** on side **B** - version ...4WEH16.../...20...
- stroke limiter on side **A** and end position monitor **contact maker** on side **B** - version ...4WEH16.../...24...
- stroke limiter on side **B** and end position monitor **contact breaker** on side **A** - version ...4WEH16.../...21...
- stroke limiter on side **B** and end position monitor **contact maker** on side **A** - version ...4WEH16.../...25...

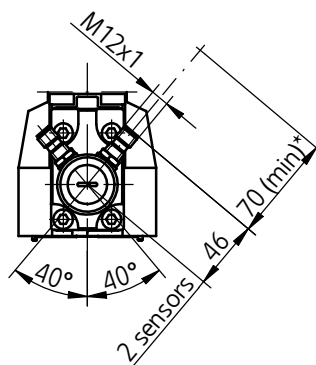

...4WEH16.../...20...  
...4WEH16.../...24...

2 solenoids (on side **a**, **b**) only for versions 4WEH16H.../O...; OF...

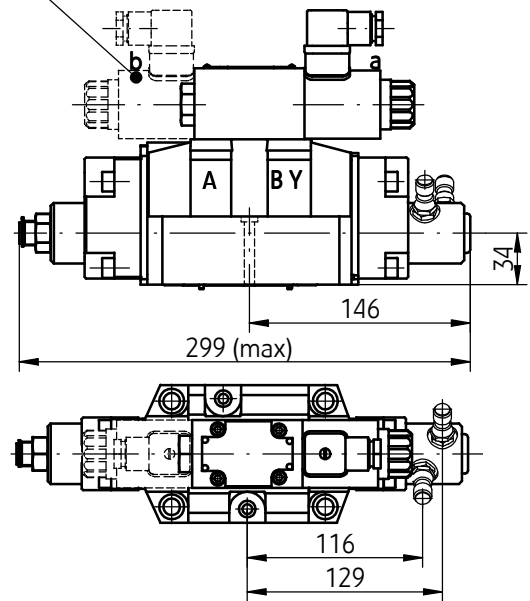

...4WEH16.../...21...  
...4WEH16.../...25...

2 solenoids (on side **a**, **b**) only for versions 4WEH16H.../O...; OF...

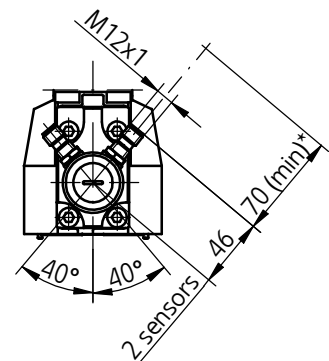
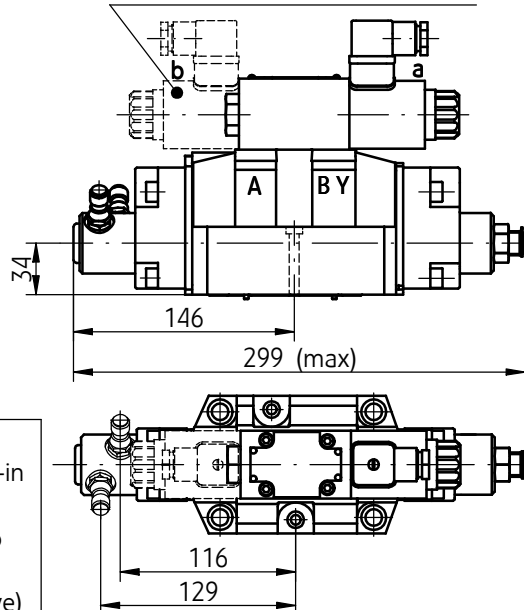

### NOTE:

(\*) - Distance for mounting plug-in connector and cable of sensor (plug-in connectors according to page 4 - 2 pcs not shown on drawing, delivered with the valve)

## EXAMPLE OF APPLICATION IN HYDRAULIC SYSTEM

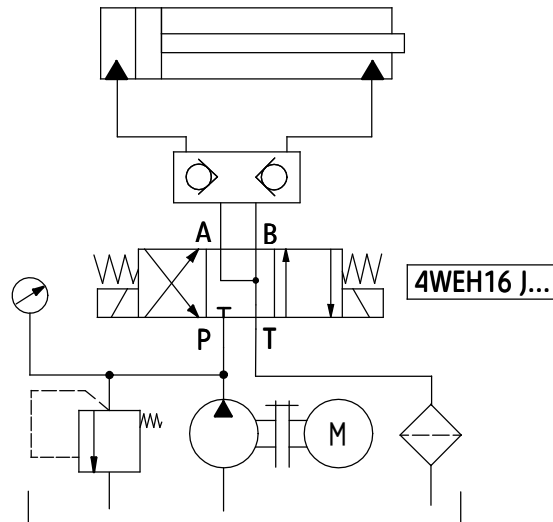

### SUBPLATES AND FIXING SCREWS

Subplates must be ordered according to Data Sheet  
**WK 450 788**. Subplate types:

<b>G174/01</b> - threaded connections	<b>P, T, A, B - G 1</b> <b>X, Y, L - G1/4</b>
G174/02 - threaded connections	P, T, A, B - M33 x 2 X, Y, L - M14 x 1,5
G172/01 - threaded connections	P, T, A, B - G3/4 X, Y, L - G1/4
G172/02 - threaded connections	P, T, A, B - M27 x 2 X, Y, L - M14 x 1,5

Fixing screws for mounting directional spool valve  
in accordance with PN - EN ISO 4762:

**M10 x 60 -10,9** - 4 pcs/set

**M6 x 60 -10.9** - 2 pcs/set

must be ordered separately.

Tightening torques for screws:

**M10 x 60 - Md = 62 Nm**

**M 6 x 60 - Md = 12,5 Nm**

**NOTE:**

Subplate symbol in bold are preferred versions in  
short delivery time.

## PERFORMANCE CURVES

measured at viscosity  $\nu = 41 \text{ mm}^2/\text{s}$  and temperature  $t = 50^\circ\text{C}$

### Flow resistance curves

Performance curves  $\Delta p(Q)$  for directional valve type ...4WEH16... with spools **E** and **R**

1 - spools: **E, R**

2 - spool **R** - flow direction **P→A** and **B→A**

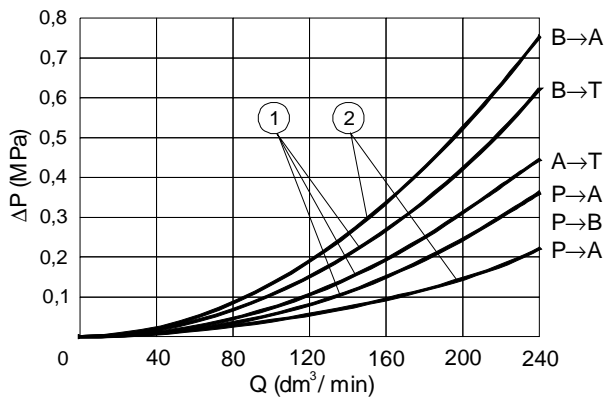

Performance curves  $\Delta p(Q)$  for directional valve type ...4WEH16... with spools: **F, H, J, L, M, Q, S, U, V, W, C, D, D1, K, Z**

1 - spool **S**

2 - spools: **F, H, J, L, M, Q, U, V, W, C, D, K, Z**

3 - spool **D1**

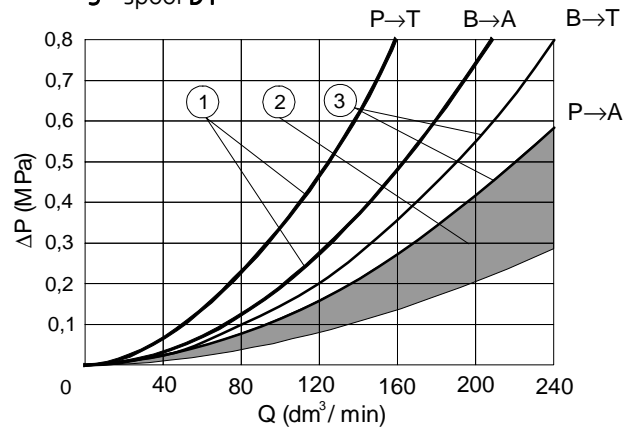

Performance curves  $\Delta p(Q)$  for directional valve type 4WEH16... with spools **G** and **T**

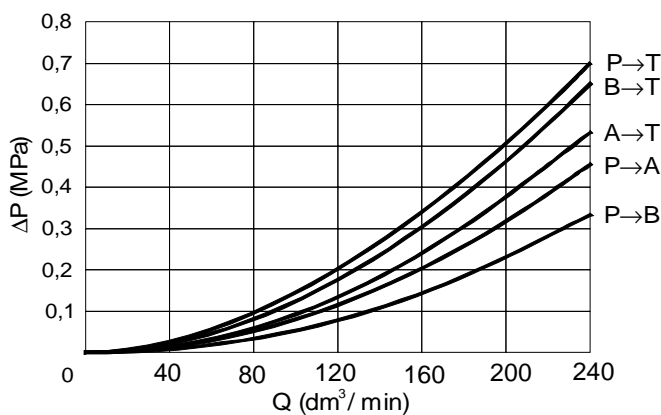

### Operating limits

spool type (diagrams see page 8)	pressure p [MPa]				
	7	14	21	28	35
flow rate Q [dm <sup>3</sup> /min]					
<b>E, J, L, M, Q, R, U, V, W, C, D, K, Z</b>	240	240	205	180	170
<b>F</b>	200	145	115	100	90
<b>G, H, S, T</b>	220	160	130	110	100

## HOW TO ORDER

+	4	WEH				/						+
---	---	-----	--	--	--	---	--	--	--	--	--	---

**Design version** - working pressure  
**up to 28 MPa = no designation**  
**up to 35 MPa = H**

**Number of service ports**  
**4-way = 4**

**Nominal size (NS)**  
**NS16 = 16**

**Centering/ spool positioning of the main valve**  
**spring centering = no designation**  
 hydraulic off -set = H

**Symbol of the main spool**  
**spool diagrams - according to page 8**

**Series number**  
 (70-79) - installation and connection dimensions unchanged = 7X  
**series 73 = 73**

**Centering/positioning of spool of the pilot valve** (applicable only to  
 2-position versions WEH16HC... / ...HD... / ...HD1.../ ...HK... / ...HZ...)  
**by means of spring** (solenoid on side a) = **no designation**  
 without spring (solenoids on side a and b) = O  
 without spring, with detent (solenoids on side a and b) = OF

**Supply voltage for solenoids at pilot valve**  
 12V DC = G12  
**24V DC = G24**  
 110V DC = G110  
 110V AC 50Hz (plug-in-connector with rectifier) = W110R  
 220V AC 50Hz (plug-in-connector with rectifier) = W220R  
**230V AC 50Hz (plug-in-connector with rectifier) = W230R**  
 230V AC 50 Hz (direct supply with AC current) = W230-50

**Manual override**  
**solenoids with manual override = N**  
 solenoids without manual override - only versions  
 with spool position sensor type M) = no designation

**Pilot oil supply and pilot oil drain**  
**external pilot oil supply, external pilot oil drain = no designation**  
 internal pilot oil supply, external pilot oil drain = E  
 internal pilot oil supply, internal pilot oil drain = ET  
 external pilot oil supply, internal pilot oil drain = T

**Switching time adjustment**  
**without switching time adjustment = no designation**  
 switching time adjustment as meter-in control = S  
 switching time adjustment as meter-out control = S2

**Electrical connection**  
**plug-in-connector type ISO 4400 (DIN 43650 - A) without LED = Z4**  
 plug-in-connector type ISO 4400 (DIN 43650 - A) with LED = Z4L  
 connector type AMP Junior Timer, 2-poles male - for...G12...; ...G24... options only; without plug-in-connector = J  
 connector type DEUTSCH DT04 -2P - for ...G24... option only; without plug-in-connector = D

## HOW TO ORDER

+						★
---	--	--	--	--	--	---

Further requirements in clear text  
(to be agreed with the manufacturer)

### Sealing

**NBR** (for fluids on mineral oil base) = **no designation**  
FKM (for fluids on phosphate ester base) = V

### Pressure ratio valve

**without pressure ratio valve** = **no designation**  
with pressure ratio valve = D1

### Pre-load valve

**without pre-load valve** = **no designation**  
pre-load valve with cracking pressure 0,45 MPa = P 4,5  
pre-load valve with cracking pressure 0,7 MPa = P 7

### Throttle insert in port P of the pilot valve

**without throttle insert** = **no designation**  
throttle insert  $\phi$  0,8 = B 08  
throttle insert  $\phi$  1,0 = B 10  
throttle insert  $\phi$  1,2 = B 12

### Accessories

(for versions with spool position sensor type **M** available options ...11... ...12... only)

**without accessories** = **no designation**  
stroke limiter on valve ends **A** and **B** = 10  
stroke limiter on valve end **A** \* = 11  
stroke limiter on valve end **B** \*\* = 12  
end position monitor contact breaker on valve end **A** = 18  
end position monitor contact breaker on valve end **B**  
(not applicable for 2-position valves with spring positioning) = 19  
stroke limiter on valve end **A** and end position monitor contact breaker on valve end **B** = 20  
stroke limiter on valve end **B** and end position monitor contact breaker on valve end **A** = 21  
end position monitor contact maker on valve end **A** = 22  
end position monitor contact maker on valve end **B**  
(not applicable for 2-position valves with spring positioning) = 23  
stroke limiter on valve end **A** and end position monitor contact maker on valve end **B** = 24  
stroke limiter on valve end **B** and end position monitor contact maker on valve end **A** = 25

### Spool position sensor type **M**

**without spool position sensor** = **no designation**  
**0** - zero position monitoring (*3-position versions, springs centered*  
*and 2-position versions with positions (a, 0) or (0, b)*) = M0  
**a** position monitoring (*3-position versions with 1 sensor at the B side*  
*and 2-position versions with positions (a, 0) or (a, b)*) = MA  
**b** position monitoring (*3-position versions with 1 sensor*  
*and 2-position versions with positions (0, b) or (a, b)*) = MB  
**a and b** position monitoring (*3-position versions, springs centered*  
*and 2-position hydraulically positioned versions*  
*with 2 sensors at the A and B side*) = MAB

### NOTES:

Optional accessories for versions with sensor type **M**:

(\*) - version ...11... available only for ...MA... in a 3-position version (sensor at the side of port **B**, **a** position monitoring)

(\*\*) - version ...12... available only for ...MB... in a 3-position version (sensor at the side of port **A**, **b** position monitoring)

The directional spool valve should be ordered according to the above coding.

The symbols in bold indicate the preferred versions, available in short delivery time.

Coding example: H- 4 WEH16 E 13/G24 N ET Z4

PONAR Wadowice S.A.  
ul. Wojska Polskiego 29  
34-100 Wadowice  
tel. +48 33 488 29 00  
fax. +48 33 488 21 03  
[www.ponar-wadowice.pl](http://www.ponar-wadowice.pl)

