

MODEL
NCFB

Fully adjustable needle valve with reverse flow check
CAPACITY: 120 L/min. (9,7 mm) | CAVITY: T-16A

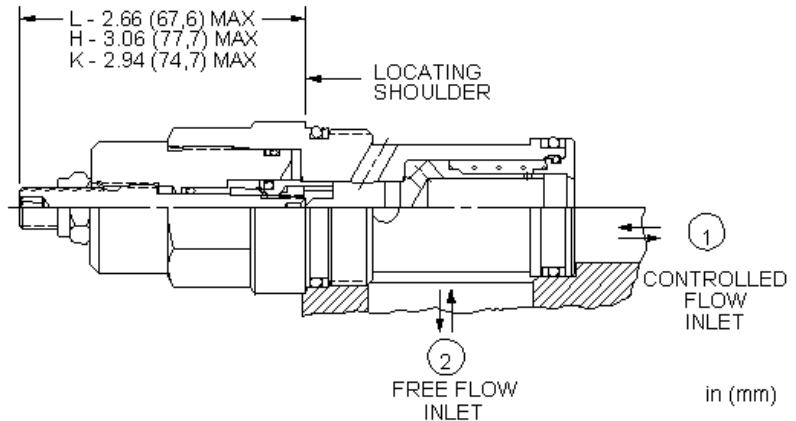
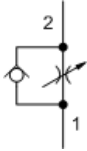

CONFIGURATION

L	Control	Standard Screw Adjustment
C	Reverse Flow Check	30 psi (2 bar)
N	Seal Material	Buna-N
(none)	Material/Coating	Standard Material/Coating

Needle valves with reverse-flow check are fully adjustable orifices used to regulate flow. They are infinitely adjustable from fully closed up to the maximum orifice diameter. An integral high-capacity check valve provides unrestricted flow from port 2 to port 1. They are not pressure-compensated.

TECHNICAL DATA

Cavity	T-16A
Series	3
Capacity	120 L/min. (9,7 mm)
Maximum Operating Pressure	350 bar
Maximum Valve Leakage at 110 SUS (24 cSt)	0,7 cc/min.
Adjustment - Number of Counterclockwise Turns - Fully Closed to Fully Open	5
Valve Hex Size	31,8 mm
Valve Installation Torque	203 - 217 Nm
Adjustment Screw Internal Hex Size	4 mm
Locknut Hex Size	15 mm
Locknut Torque	9 - 10 Nm
Seal kit - Cartridge	Buna: 990-016-007
Seal kit - Cartridge	Polyurethane: 990-016-002
Seal kit - Cartridge	Viton: 990-016-006
Model Weight	0.57 kg.

TECHNICAL FEATURES

- All 2-port flow control cartridges are physically and functionally interchangeable (i.e. same flow path, same cavity for a given frame size). However, cartridge extension dimensions from the mounting surface may vary.
- Because needle valves are non-compensating devices, the fixed orifice size will regulate flow through the valve in proportion to the square root of the pressure differential across ports 1 and 2.
- A balanced adjustment mechanism allows for easy adjustment even at high pressures.
- The sharp-edged orifice design minimizes flow variations due to viscosity changes.
- Incorporates the Sun floating style construction to minimize the possibility of internal parts binding due to excessive installation torque and/or cavity/cartridge machining variations.

PERFORMANCE CURVES

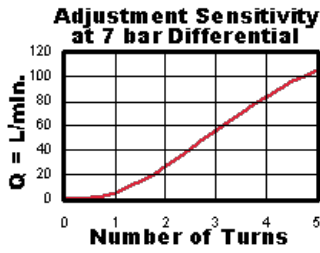
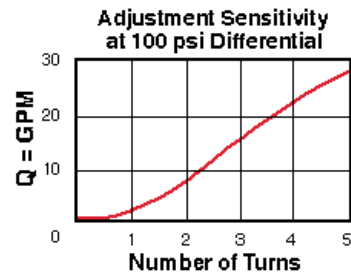
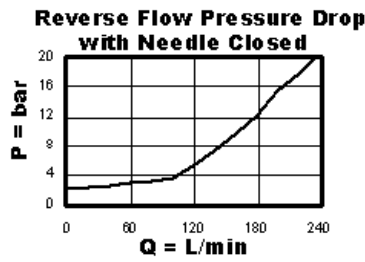
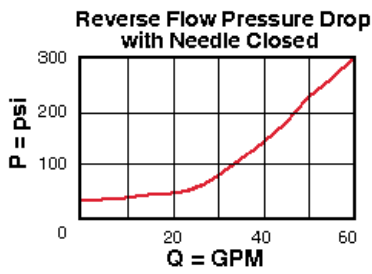

CONFIGURATION OPTIONS

CONTROL

Preferred Options	L	Standard Screw Adjustment
	H	Calibrated Handknob with Detent Lock
Standard Options	K	Handknob
	Y	Tri-Grip Handknob

REVERSE FLOW CHECK

Preferred Options	C	30 psi (2 bar)
Standard Options	A	4 psi (0,3 bar)
	E	75 psi (5 bar)

SEAL MATERIAL

Preferred Options	N	Buna-N
Standard Options	V	Viton

MATERIAL/COATING

Standard Options		Standard Material/Coating
	/AP	Stainless Steel, Passivated

Copyright © 2002-2014 Sun Hydraulics Corporation. All rights reserved.