

MODEL  
CVGV

Vented pilot-to-open check valve  
CAPACITY: 240 L/min. | CAVITY: T-23A

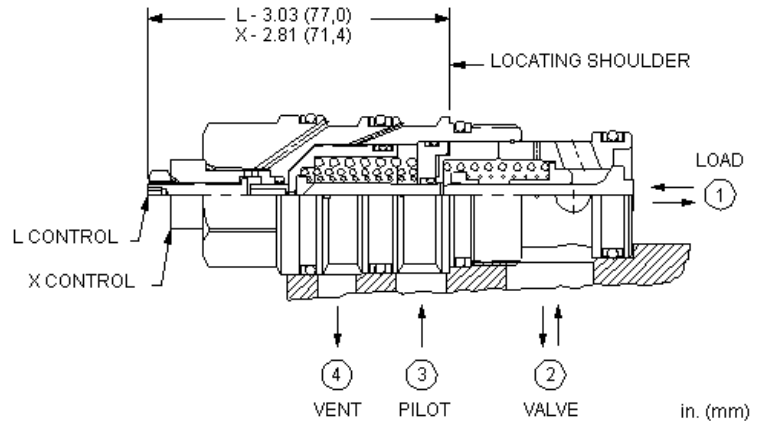
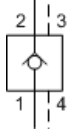

### CONFIGURATION

<b>X</b>	Control	Standard Pilot
<b>C</b>	Cracking Pressure	30 psi (2 bar)
<b>N</b>	Seal Material	Buna-N
<b>(none)</b>	Material/Coating	Standard Material/Coating

This valve is a pilot to open check valve. It has a sealed pilot, a steel seat, and is vented. It allows free flow from the valve (port 2) to the load (port 1) and blocks flow in the opposite direction. Pressure at the pilot (port 3) will open the valve from port 1 to port 2. Pilot pressure needed to open the valve is directly proportional to the load pressure at port 1. The valve is insensitive to pressure at port 2 because the spring chamber is referenced to the vent (port 4).

### TECHNICAL DATA

Cavity	T-23A
Series	3
Capacity	240 L/min.
Pilot Ratio	3:1
Maximum Operating Pressure	350 bar
Maximum Valve Leakage at 110 SUS (24 cSt)	0,07 cc/min.
Valve Hex Size	31,8 mm
Valve Installation Torque	203 - 217 Nm
Seal kit - Cartridge	Buna: 990-023-007
Seal kit - Cartridge	Polyurethane: 990-023-002
Seal kit - Cartridge	Viton: 990-023-006
Model Weight	0.68 kg.

### SYMBOLS

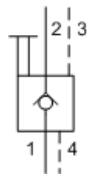
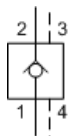

### TECHNICAL FEATURES

- Pilot pressure as low as 75 psi (5 bar) higher than the pressure at the vent can prevent the valve from closing.
- Will accept pressure at port 4 (vent) but can not exceed 5000 psi (350 bar).
- Pilot-to-open check cartridges are locking valves, not motion control valves. For motion control applications, use counterbalance valves.

- Four-port pilot-to-open check cartridges and four-port counterbalance cartridges are physically interchangeable (i.e. same cavities, same flow path for a given frame size). However, cartridge extension dimensions from the mounting surface may vary.
- Approximately 1 drop (0,07 cc) of fluid will pass from the pilot area to the vented spring chamber every 4000 cycles.
- Provides hose break protection, prevents loads from drifting and positively locks pressurized loads.
- Extremely low leakage. The seat and poppet are heat treated for long life. If the load drifts due to the valve, the seat has probably been damaged by contamination and the valve should be replaced.
- Sealed pilot for use in circuits where cross port leakage is undesirable.
- Port 4 (vent) should never be blocked as seal weepage will eventually cause valve to malfunction.
- Incorporates the Sun floating style construction to minimize the possibility of internal parts binding due to excessive installation torque and/or cavity/cartridge machining variations.

## PERFORMANCE CURVES

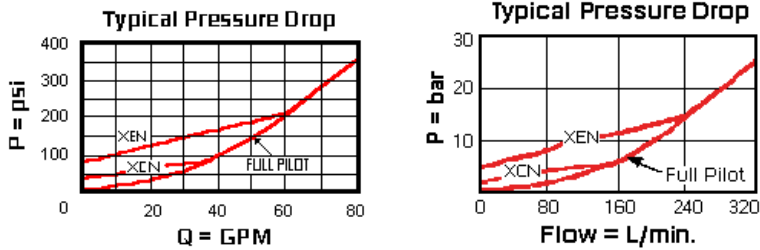

## CONFIGURATION OPTIONS

### CONTROL

Preferred Options	X	Standard Pilot
Standard Options	L	Manual Load Release

### CRACKING PRESSURE

Preferred Options	C	30 psi (2 bar)
	A	4 psi (0,3 bar)
	B	15 psi (1 bar)
Standard Options	D	50 psi (3,5 bar)
	E	75 psi (5 bar)
	F	100 psi (7 bar)

### SEAL MATERIAL

Preferred Options	N	Buna-N
Standard Options	V	Viton

### MATERIAL/COATING

		Standard Material/Coating
Standard Options	/AP	Stainless Steel, Passivated
	/LH	Mild Steel, Zinc-Nickel

Copyright © 2002-2014 Sun Hydraulics Corporation. All rights reserved.