

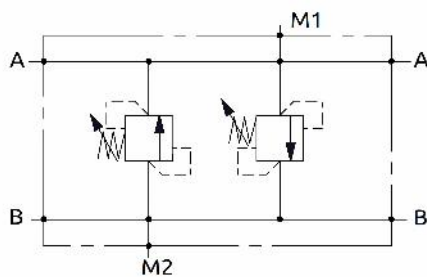

Valvola limitatrice di pressione doppia incrociata Dual cross-over relief valve



CURVE CARATTERISTICHE
PERFORMANCE CURVES

3/8"G - 1/2"G

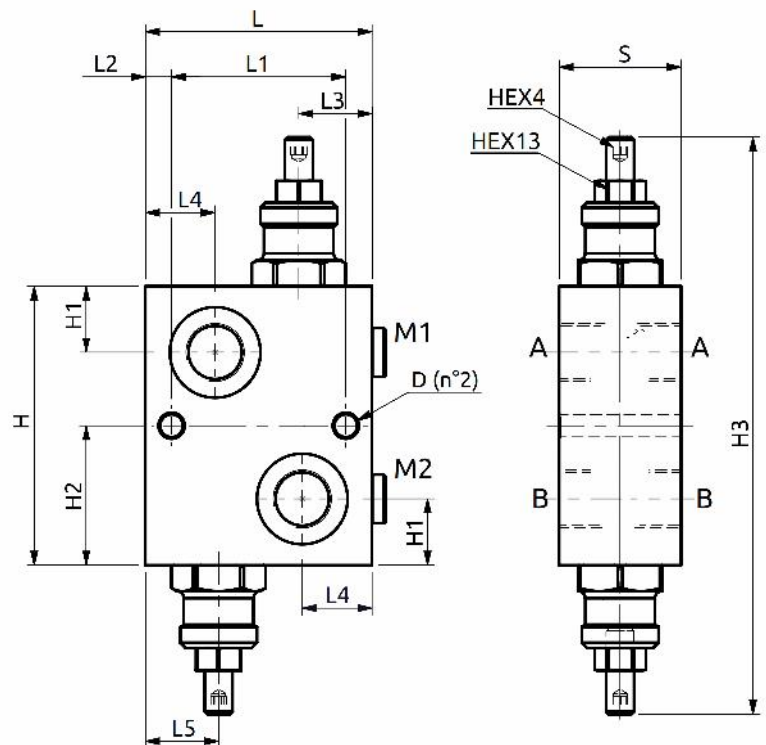
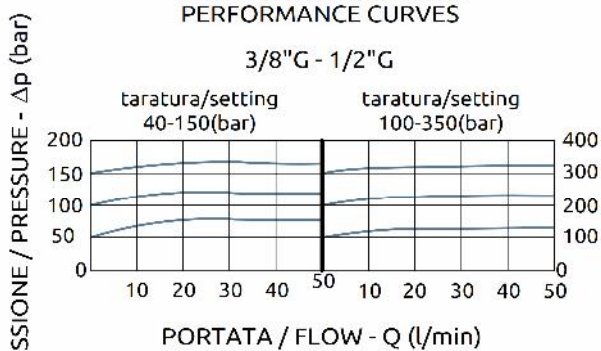

Corpo in acciaio / Steel body

65	50	7.5	21	20	21	35	80	19	40	~166	Ø6.5
L	L1	L2	L3	L4	L5	S	H	H1	H2	H3	D

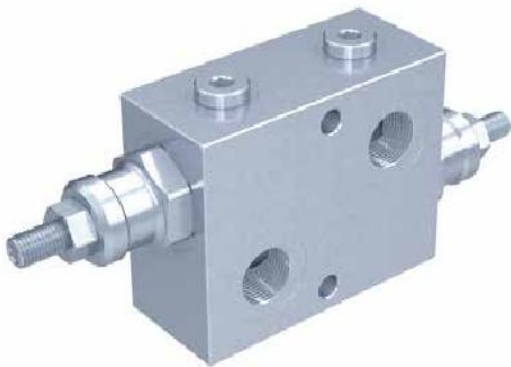

DESCRIZIONE

Valvola limitatrice di pressione doppia incrociata con tenuta ad otturatore, con funzione di protezione del circuito da sovrappressioni. Disponibile con due differenti campi di taratura.

DESCRIPTION

Dual relief valve in compact steel construction poppet type, for overload protection. Two setting ranges available.

CODICE ORDINAZIONE PIOMBATURA

SEALING ORDERING CODE

916003

Codice Ordinazione	Campo di Taratura	Taratura Standard	Incremento per giro	Portata Massima	Pressione Max	Dimensione Porte	Peso
Ordering Code	Pressure Range	Standard Setting	Pressure Increase	Max Flow	Max Pressure	Port Size	Weight
A010302.11.00	40-150 bar	80 bar	25 bar/turn	50 l/min	400 bar	3/8"G	1.3 kg
A010302.12.00	100-350 bar	250 bar	100 bar/turn	50 l/min	400 bar	3/8"G	1.3 kg
A010402.11.00	40-150 bar	80 bar	25 bar/turn	65 l/min	400 bar	1/2"G	1.3 kg
A010402.12.00	100-350 bar	250 bar	100 bar/turn	65 l/min	400 bar	1/2"G	1.3 kg