

**VBSO-DE-NA**

**05.42.25 - X - Y - Z**

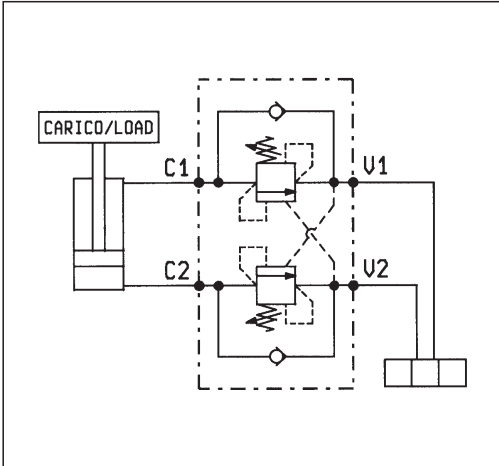

DATI TECNICI / TECHNICAL DATA	
Pressione max. Max. pressure	350 bar
Portata max. Flow max.	220 l/min
Taratura della valvola: almeno 1.3 volte superiore alla pressione indotta dal carico Pressure setting: at least 1.3 times the load induced pressure	
Cappello per piombatura Sealing Cap	Codice/Ordering code 03.05.01.005
Peso Weight	7.25 kg

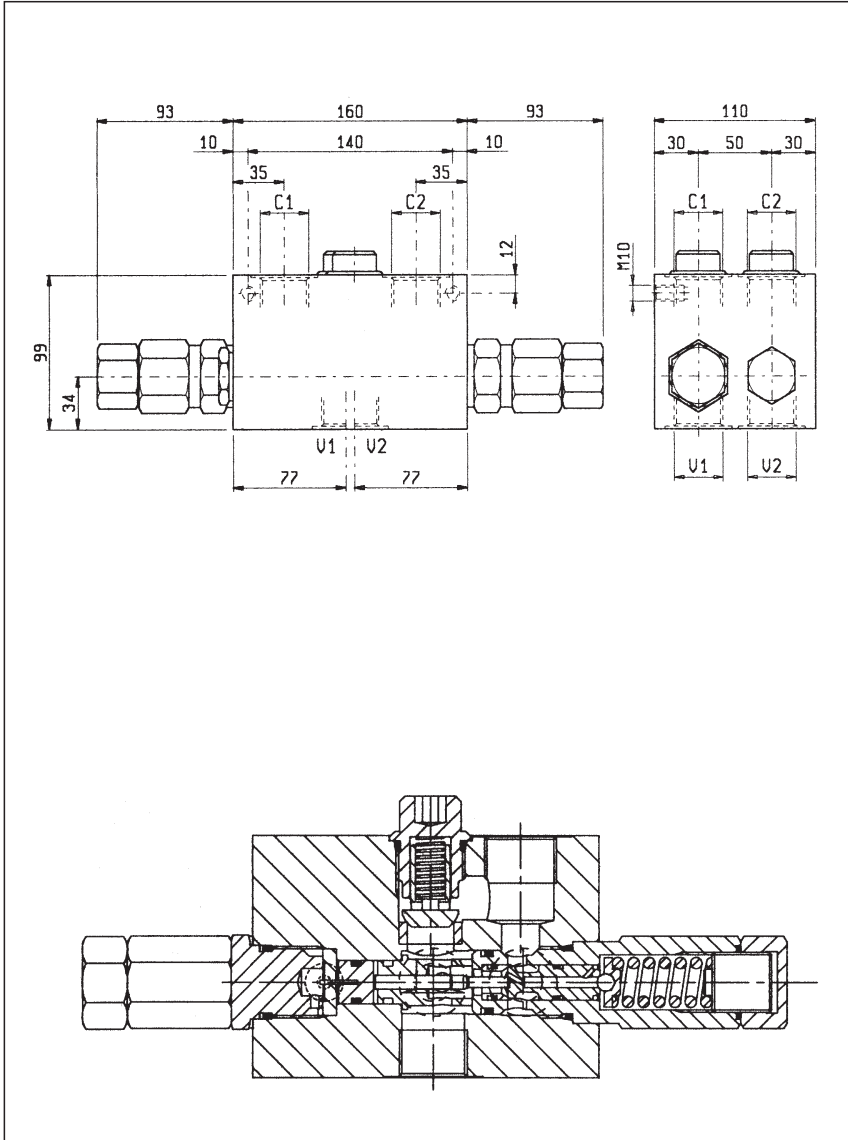
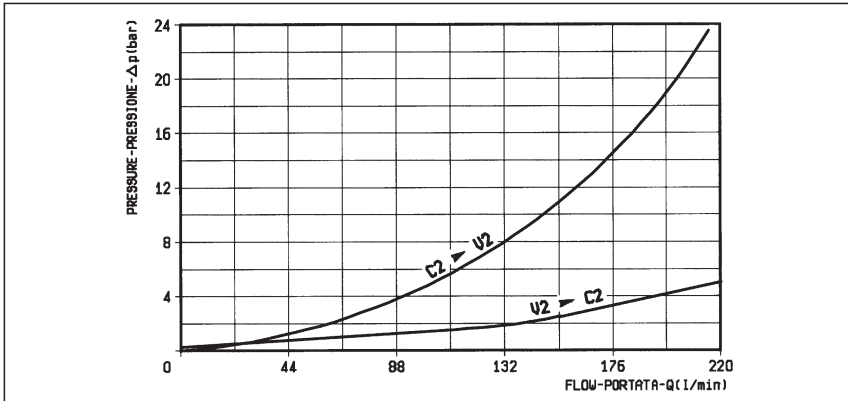

X	RAPPORTO DI PILOTAGGIO PILOT RATIO
03	8.1 : 1
10	2.8 : 1

Z	MOLLE / SPRINGS				
	Campo taratura min - max bar Adj. press. range bar	Incremento press. bar / giro vite Press. increase bar / turn	Taratura standard bar (Q = 5 l/min) Std. setting bar (made at = 5 l/min)	Cod. ordinazione Ordering code	Colore Colour
20	60-210	36	200	03.51.01.067	verde green
35	120-350	62	350	03.51.01.057	giallo yellow

Y	ATTACCHI / PORT SIZE	
	V1-V2-C1-C2	
05	G 1	