

MODEL
SCEA

Direct-acting sequence valve with reverse flow check
CAPACITY: 120 L/min. | CAVITY: T-2A

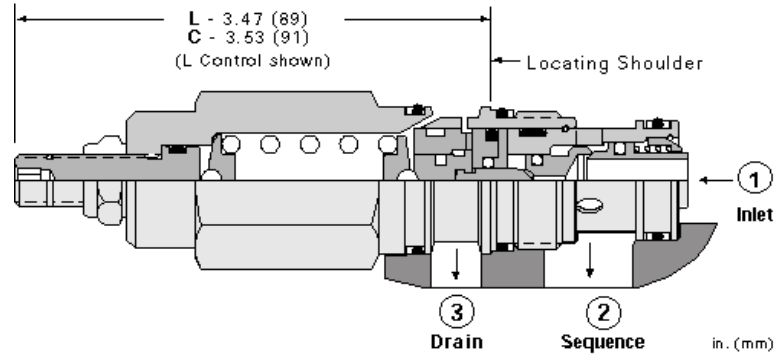
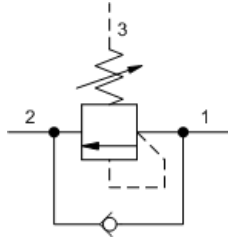

CONFIGURATION

L	Control	Standard Screw Adjustment
A	Adjustment Range	500 - 3000 psi (35 - 210 bar), 1000 psi (70 bar) Standard Setting
N	Seal Material	Buna-N
(none)	Material/Coating	Standard Material/Coating

Direct-acting sequence valves with reverse-flow check will supply a secondary circuit with flow once the pressure at the inlet (port 1) has exceeded the valve setting. Additionally, these valves incorporate an integral check valve to provide reverse flow from port 2 (sequence) to port 1 (inlet). The pressure setting of a sequence valve controls the pressure at port 1 relative to the pressure at the drain (port 3).

TECHNICAL DATA

Cavity	T-2A
Series	2
Capacity	120 L/min.
Factory Pressure Settings Established at	30 cc/min.
Maximum Operating Pressure	350 bar
Response Time - Typical	2 ms
Maximum Valve Leakage at Reseat	0,7 cc/min.
Check Cracking Pressure	1,7 bar
Adjustment - Number of Clockwise Turns to Increase Setting	5
Valve Hex Size	28,6 mm
Valve Installation Torque	61 - 68 Nm
Adjustment Screw Internal Hex Size	4 mm
Locknut Hex Size	15 mm
Locknut Torque	9 - 10 Nm
Seal kit - Cartridge	Buna: 990-202-007
Seal kit - Cartridge	Polyurethane: 990-002-002
Seal kit - Cartridge	Viton: 990-202-006
Model Weight	0.37 kg.

SYMBOLS

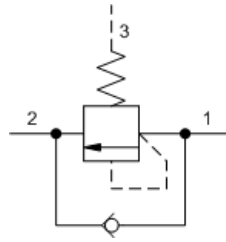
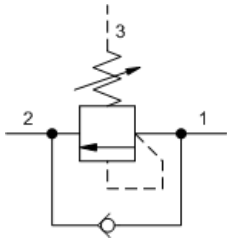

TECHNICAL FEATURES

- All 3 port sequence cartridges are physically and functionally interchangeable (i.e. same flow path, same cavity for a given frame size).
- Although this is a zero pilot flow valve, port 3 (drain) must be connected to maintain a pressure reference in the control chamber. If port 3 is blocked, reciprocating seal weepage will cause the valve to malfunction.
- Pressure at port 3 is directly additive to the valve setting at a 1:1 ratio and should not exceed 5000 psi (350 bar).
- Suitable for use in load holding applications.
- Incorporates the Sun floating style construction to minimize the possibility of internal parts binding due to excessive installation torque and/or cavity/cartridge machining variations.

PERFORMANCE CURVES

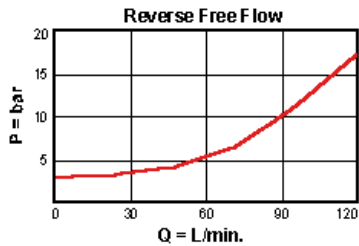
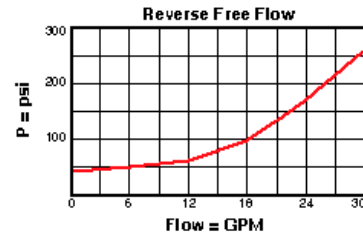
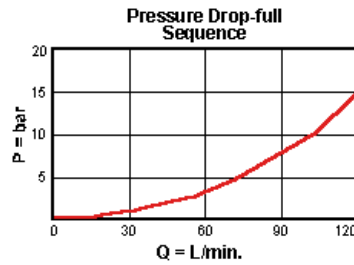
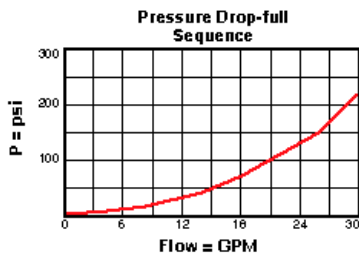

CONFIGURATION OPTIONS

CONTROL

Preferred Options	L	Standard Screw Adjustment
Standard Options	C	Tamper Resistant - Factory Set

ADJUSTMENT RANGE

Preferred Options	A	500 - 3000 psi (35 - 210 bar), 1000 psi (70 bar) Standard Setting
	W	800 - 4500 psi (55 - 315 bar), 1000 psi (70 bar) Standard Setting
Standard Options	B	300 - 1500 psi (20 - 105 bar), 1000 psi (70 bar) Standard Setting
	C	2000 - 6000 psi (140 - 420 bar), 2000 psi (140 bar) Standard Setting
	D	200 - 800 psi (14 - 55 bar), 400 psi (28 bar) Standard Setting
	E	100 - 400 psi (7 - 28 bar), 200 psi (14 bar) Standard Setting

SEAL MATERIAL

Preferred Options **N** Buna-N

Standard Options **V** Viton

MATERIAL/COATING

Standard Options **/AP** Standard Material/Coating
Stainless Steel, Passivated

Copyright © 2002-2014 Sun Hydraulics Corporation. All rights reserved.