

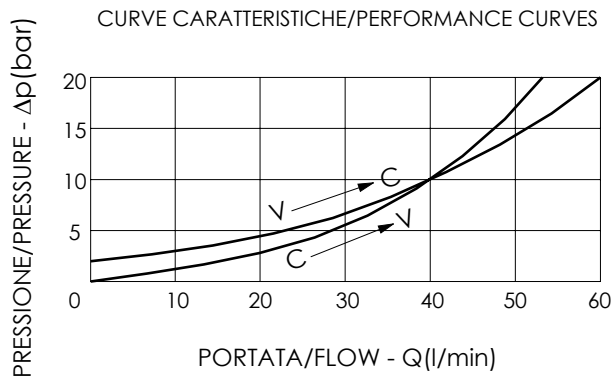

VALVOLA DI BLOCCO A CARTUCCIA PILOTATA
PILOT OPERATED CHECK VALVE CARTRIDGE TYPE

SEDE/CAVITY

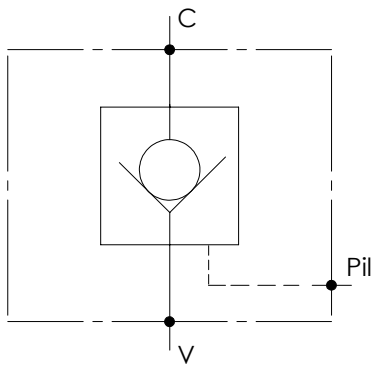
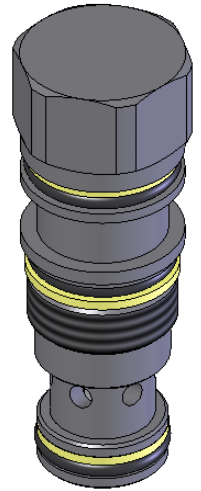
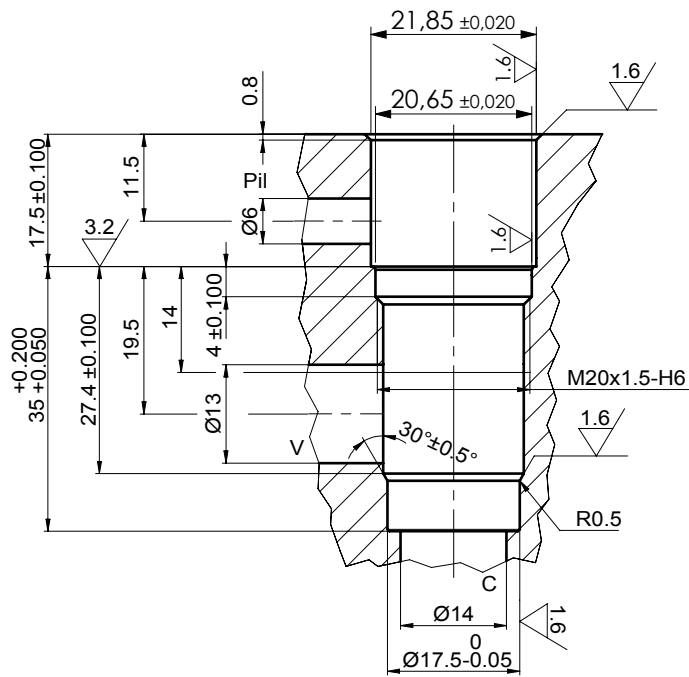
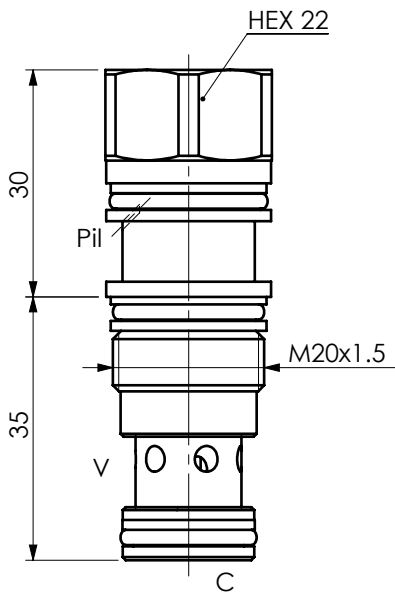

CODICE ORDINAZIONE ORDERING CODE	RAPPORTO DI PILOTAGGIO PILOT RATIO	CAMPO DI PORTATA (l/min) FLOW RANGE (l/min)	PRESSIONE DI INIZIO APERTURA (bar) CRACKING PRESSURE (bar)	PRESSIONE MAX (bar) MAXIMUM PRESSURE (bar)	PESO (Kg) WEIGHT (Kg)
C052101.02.00	4:1	0-60	2	350	0.12