

MODEL  
CKGA

Pilot-to-open check valve with standard pilot and Delrin seat  
CAPACITY: 240 L/min. | CAVITY: T-17A

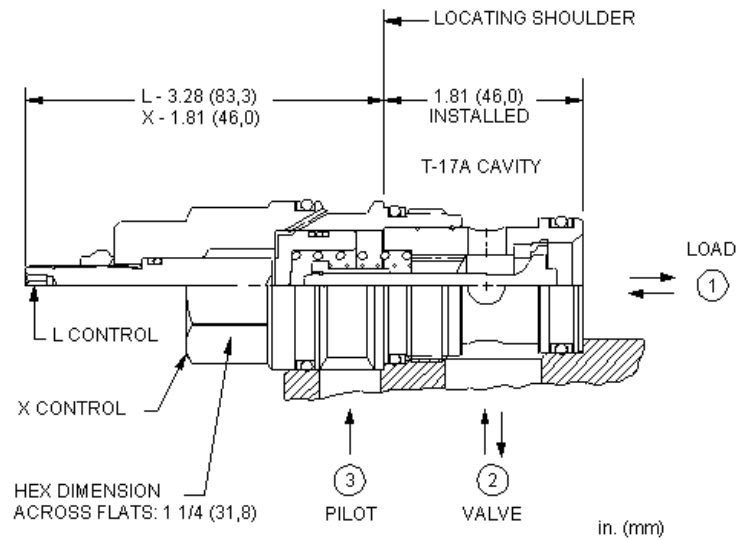
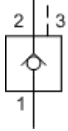

### CONFIGURATION

<b>X</b>	Control	Standard Pilot
<b>C</b>	Cracking Pressure	30 psi (2 bar)
<b>N</b>	Seal Material	Buna-N

This valve is a pilot to open check valve. It has a non-sealed pilot, a Delrin seat, and is non-vented. It allows free flow from the valve (port 2) to the load (port 1) and blocks flow in the opposite direction. Pressure at the pilot (port 3) will open the valve, allowing flow from port 1 to port 2. Pilot pressure needed at port 3 to open the valve is directly proportional to the load pressure at port 1. Pressure at port 2 directly opposes pilot pressure.

### TECHNICAL DATA

Cavity	T-17A
Series	3
Capacity	240 L/min.
Pilot Ratio	3:1
Maximum Operating Pressure	175 bar
Maximum Valve Leakage at 110 SUS (24 cSt)	0,07 cc/min.
Valve Hex Size	31,8 mm
Valve Installation Torque	203 - 217 Nm
Seal kit - Cartridge	Buna: 990-017-007
Seal kit - Cartridge	Polyurethane: 990-017-002
Seal kit - Cartridge	Viton: 990-017-006
Model Weight	0.52 kg.

### SYMBOLS

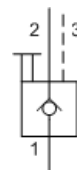
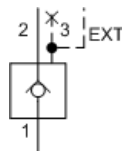
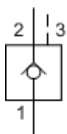

## TECHNICAL FEATURES

- This 3 port pilot-to-open check valve and 3 port counterbalance valves are physically interchangeable (i.e. same cavities, same flow path for a given frame size). However, cartridge extension dimensions from the mounting surface may vary.
- Provides hose break protection, prevents loads from drifting and positively locks pressurized loads.
- Standard unsealed pilot allows air trapped in the pilot line to be purged from the circuit.
- Optional external porting out of the hex end of the cartridge is available for external piloting. In this configuration, port 3 is blocked. See Control options E, and P.
- Pilot-to-open check cartridges are locking valves, not motion control valves. For motion control applications, use counterbalance valves.
- The Delrin seat is suitable for dirty, medium pressure systems that are not subjected to high flows or temperatures.
- Extremely low leakage. If the load drifts due to the valve, the seat has probably been damaged by contamination and the valve should be replaced.
- For models with manual load release control option, turn load release clockwise to release load.
- Incorporates the Sun floating style construction to minimize the possibility of internal parts binding due to excessive installation torque and/or cavity/cartridge machining variations.

## PERFORMANCE CURVES

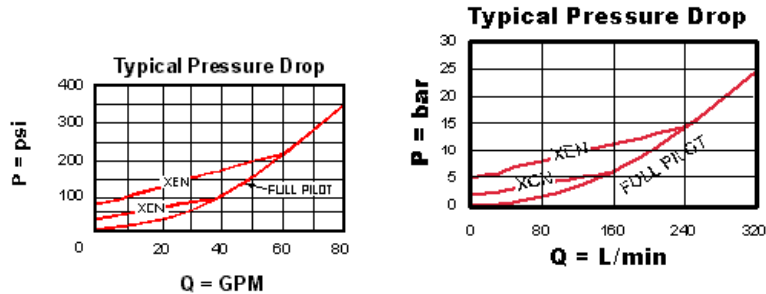

## CONFIGURATION OPTIONS

### CONTROL

Standard Options	L	Manual Load Release
	X	Standard Pilot

### CRACKING PRESSURE

Standard Options	A	4 psi (0,3 bar)
	B	15 psi (1 bar)
	C	30 psi (2 bar)
	D	50 psi (3,5 bar)
	E	75 psi (5 bar)
	F	100 psi (7 bar)

### SEAL MATERIAL

Standard Options	N	Buna-N
	V	Viton

Copyright © 2002-2014 Sun Hydraulics Corporation. All rights reserved.