

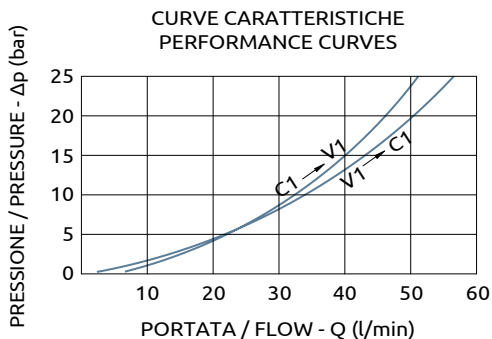

Valvola di blocco bilanciata semplice serie 165 flangiabile per motori idraulici
Dual overcenter valve "165 series", flangeable for hydraulics motors

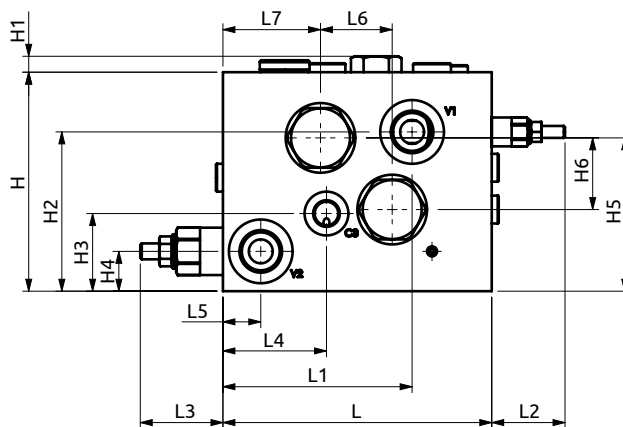
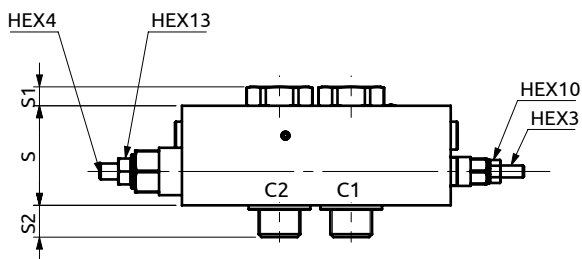
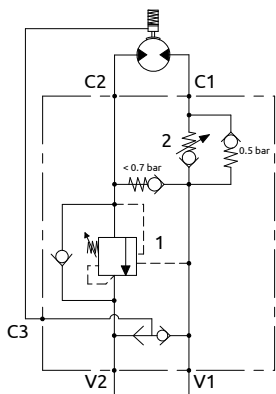

Corpo in alluminio / Aluminium body

B060491.03.00	135	95	~36.8	~41.5	52	19	36	49	50	9.5	16	110	8	80	39	20	77	36
COD.	L	L1	L2	L3	L4	L5	L6	L7	S	S1	S2	H	H1	H2	H3	H4	H5	H6

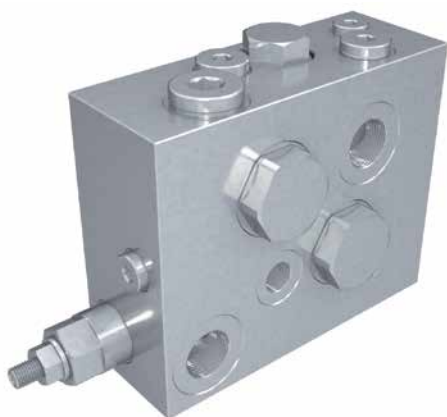

DESCRIZIONE	DESCRIPTION
Valvola di blocco bilanciata semplice con bulloni per motori danfoss OMR, OMP.	Single overcenter valve for danfoss motors OMR, OMP.
CODICE ORDINAZIONE PIOMBATURA	SEALING ORDERING CODE
916003	

Codice Ordinazione	Rapporto di Pilotaggio	Campo di Taratura	Taratura Standard	Incremento per Giro	Portata Massima	Pressione Max	Dimensione Porte	Peso
Ordering Code	Pilot Ratio	Pressure Range	Standard Setting	Pressure Increase	Max Flow	Max Pressure	Port Size	Weight
B060491.03.00	1	8.75:1	50-220 bar	210 bar	55 bar/turn	60 l/min	V1-V2-C1-C2	2.5 kg
	2	-	7-15	10 bar	3 bar/turn		C3	