

MODEL
CXFB

Free flow nose to side check valve
CAPACITY: 160 L/min. | CAVITY: T-3A



CONFIGURATION

X	Control	Not Adjustable
C	Cracking Pressure	30 psi (2 bar)
N	Seal Material	Buna-N
(none)	Material/Coating	Standard Material/Coating

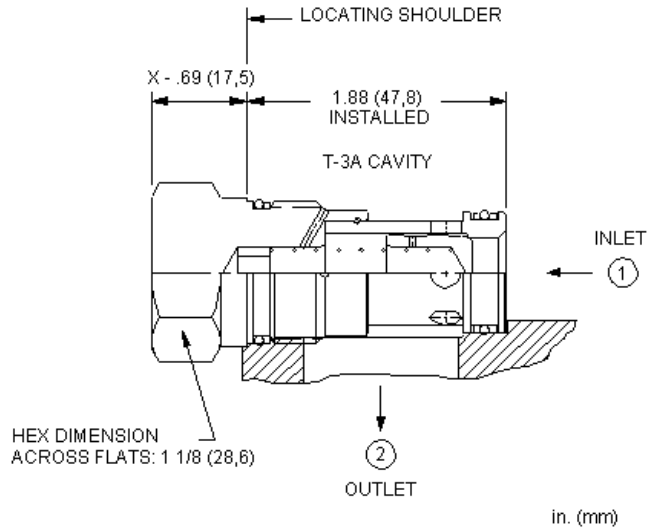

Free-flow, nose-to-side check valves are on/off circuit components that allow free flow from the inlet (port 1) to the outlet (port 2) and block flow in the opposite direction.

TECHNICAL DATA

Cavity	T-3A
Series	2
Capacity	160 L/min.
Valve Hex Size	28,6 mm
Valve Installation Torque	61 - 68 Nm
Seal kit - Cartridge	Buna: 990-203-007
Seal kit - Cartridge	Viton: 990-203-006
Model Weight	0.19 kg.

PERFORMANCE CURVES

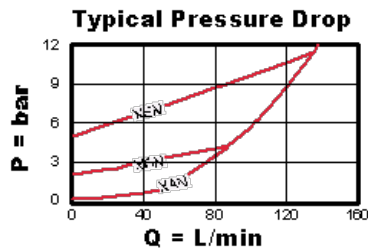
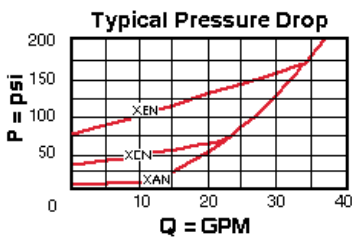

CONFIGURATION OPTIONS

CONTROL

Standard Options **X** Not Adjustable

CRACKING PRESSURE

	A	4 psi (0,3 bar)
	B	15 psi (1 bar)
	C	30 psi (2 bar)
Standard Options	D	50 psi (3,5 bar)
	E	75 psi (5 bar)
	F	100 psi (7 bar)
	Z	1 psi (0,07 bar)

SEAL MATERIAL

Standard Options	N	Buna-N
	V	Viton

MATERIAL/COATING

Standard Options		Standard Material/Coating
	/AP	Stainless Steel, Passivated

Copyright © 2002-2014 Sun Hydraulics Corporation. All rights reserved.