

MODEL  
CKGI

Vented pilot-to-open check valve with external pilot port, sealed pilot, and stem seal  
CAPACITY: 240 L/min. | CAVITY: T-17A

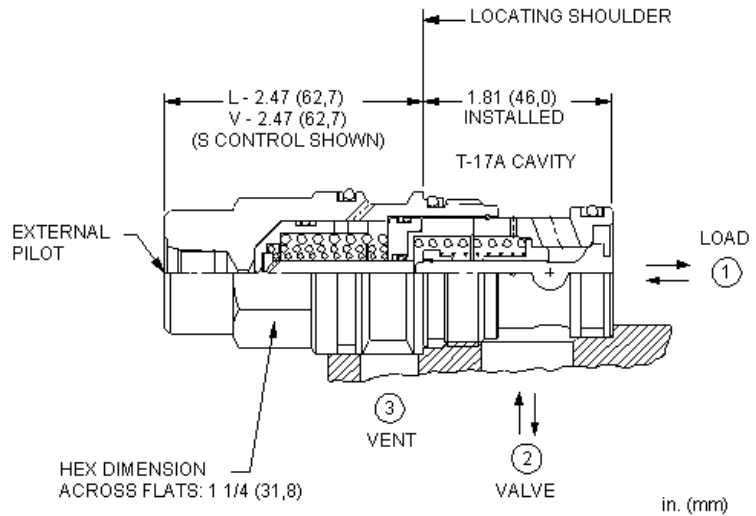
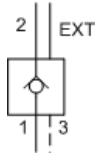

**CONFIGURATION**

<b>S</b>	Control	External 4-SAE Pilot Port, Vent to Port 3
<b>C</b>	Cracking Pressure	30 psi (2 bar)
<b>N</b>	Seal Material	Buna-N

This valve is a pilot to open check valve. It has a sealed pilot, a steel seat, and is vented. It allows free flow from the valve (port 2) to the load (port 1) and blocks flow in the opposite direction. Pressure at the external pilot port will open the valve from port 1 to port 2. Pilot pressure needed to open the valve is directly proportional to the load pressure at port 1. The valve is insensitive to pressure at port 2 because the spring chamber references the vent (port 3).

**TECHNICAL DATA**

Cavity	T-17A
Series	3
Capacity	240 L/min.
Pilot Ratio	3:1
Maximum Operating Pressure	350 bar
Maximum Valve Leakage at 110 SUS (24 cSt)	0,07 cc/min.
Valve Hex Size	31,8 mm
Valve Installation Torque	203 - 217 Nm
Seal kit - Cartridge	Buna: 990-017-007
Seal kit - Cartridge	Polyurethane: 990-017-002
Seal kit - Cartridge	Viton: 990-017-006
Model Weight	0.59 kg.

**TECHNICAL FEATURES**

- There is a positive seal between ports 2 and 3.
- These valves should be considered service items only. New applications should use valves from the CV\*V family.
- Pilot pressure as low as 75 psi (5 bar) higher than the pressure at the vent can prevent the valve from closing.
- Pilot-to-open check cartridges are locking valves, not motion control valves. For motion control applications, use counterbalance valves.
- Extremely low leakage. If the load drifts due to the valve, the seat has probably been damaged by contamination and the valve should be replaced.
- This 3 port pilot-to-open check valve is not physically interchangeable with other 3 port pilot-to-open check valves or counterbalance valves due to the different pilot/vent configuration.
- This valve is a direct replacement for the CK\*E, CK\*F, CKEG, and CK\*H and uses components from the new vented design. It does not have the proportional pressure reducing characteristic. Note: Replacing the older design with this valve can result in a 33% increase in pressure at the actuator.
- Approximately 1 drop (0,07 cc) of fluid will pass from the pilot area to the vented spring chamber every 4000 cycles.

- Provides hose break protection, prevents loads from drifting and positively locks pressurized loads.
- Sealed pilot for use in circuits where cross port leakage is undesirable.
- Incorporates the Sun floating style construction to minimize the possibility of internal parts binding due to excessive installation torque and/or cavity/cartridge machining variations.

---

## PERFORMANCE CURVES

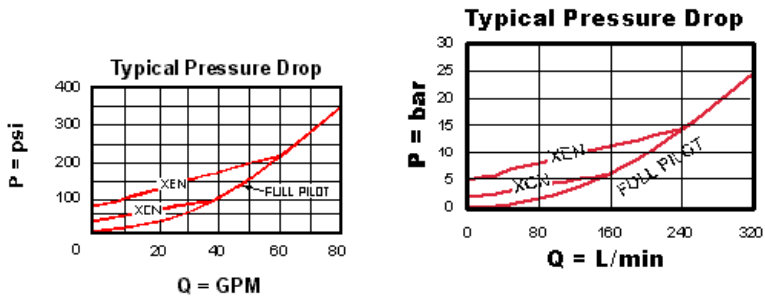

---

## CONFIGURATION OPTIONS

### CONTROL

Standard Options	S	External 4-SAE Pilot Port, Vent to Port 3
	V	External 1/4 NPTF Pilot Port, Vent to Port 3

### CRACKING PRESSURE

Standard Options	A	4 psi (0,3 bar)
	B	15 psi (1 bar)
	C	30 psi (2 bar)
	D	50 psi (3,5 bar)
	E	75 psi (5 bar)
	F	100 psi (7 bar)

### SEAL MATERIAL

Standard Options	N	Buna-N
	V	Viton

Copyright © 2002-2014 Sun Hydraulics Corporation. All rights reserved.